

Generating high gray-level resolution monochrome displays with conventional computer graphics cards and color monitors

Xiangrui Li^{a,*}, Zhong-Lin Lu^{b,*}, Pengjing Xu^a, Jianzhong Jin^a, Yifeng Zhou^{a,c}

^a Department of Neurobiology and Biophysics, University of Science and Technology of China, P.O. Box 4, Hefei, Anhui 230027, PR China

^b Department of Psychology and Biomedical Engineering and Neuroscience Graduate Program, Laboratory of Brain Processes (LOBES), University of Southern California, Los Angeles, CA 90089-1061, USA

^c Laboratory of Visual Information Processing, Institute of Biophysics, Chinese Academy of Science, Beijing 100101, PR China

Received 6 January 2003; received in revised form 13 June 2003; accepted 16 June 2003

Abstract

Display systems based on conventional computer graphics cards are capable of generating images with about 8-bit luminance resolution. However, most vision experiments require more than 12 bits of luminance resolution. Pelli and Zhang [Spatial Vis. 10 (1997) 443] described a video attenuator for generating high luminance resolution displays on a monochrome monitor, or for driving just the green gun of a color monitor. Here we show how to achieve a white display by adding video amplifiers to duplicate the monochrome signal to drive all three guns of any color monitor. Because of the lack of the availability of high quality monochrome monitors, our method provides an inexpensive way to achieve high-resolution monochromatic displays using conventional, easy-to-get equipment. We describe the design principles, test results, and a few additional functionalities.

© 2003 Elsevier B.V. All rights reserved.

Keywords: Videoswitcher; Visual stimulus; Luminance resolution; Contrast; Computer image; Trigger

1. Introduction

Computer display systems are widely used for presenting stimuli in visual psychophysics and neurophysiology experiments. A typical setup consists of a computer with a graphics card and a monitor. The computer controls the content of the video memory of the graphics card. Digital to analog converters (DACs), also on the graphics card, convert the content of video memory into analog signals (voltages) that control the monitor. For color cathode ray tube (CRT) monitors, three DACs are required to independently control the luminosity of the red (R), green (G), and blue (B) phosphors of the screen. The resolution of a DAC, the maximum number of different voltages it can generate, determines the maximum number of shades of each

color and, thus, the maximum color resolution. The actual luminance resolution of a display system also depends on other factors, such as various noises and non-linearities, but in this paper we are primarily concerned with the limit set by the maximum number of voltage levels of the DACs. We also discuss the effect of monitor non-linearity and inaccuracy of graphics card DACs.

Most computer graphics cards have three 8-bit DACs, each capable of generating 256 (2^8) voltage levels. If the CRT is capable of displaying all 256 voltages as different luminance levels, the resolution of the display system is therefore 256 shades of red, 256 shades of green, and 256 shades of blue. If we generate monochromatic displays following the common practice of setting the RGB channels to the same voltage, the system can provide 256 levels of monochromatic luminance.

Unfortunately, 256 levels of monochromatic luminance are not sufficient for presenting visual stimuli in a wide range of psychophysical and neurophysiological experiments. Most visual phenomena are independent of absolute luminance level over a very wide range of

* Corresponding authors. Tel.: +86-551-360-1436; fax: +86-551-360-7014 (X. Li); Tel.: +1-213-740-2282; fax: +1-213-746-9082 (Z.-L. Lu).

E-mail addresses: xrlu@ustc.edu.cn (X. Li), zhonglin@usc.edu (Z.-L. Lu).

luminance (Hood and Finkelstein, 1986). Instead, they depend on stimulus contrast—the luminance of a point relative to the mean luminance of its neighborhood. For displays with a constant background luminance, point contrast is defined as:

$$c(x, y, t) = \frac{L(x, y, t) - L_0}{L_0} \quad (1)$$

where $L(x, y, t)$ is the luminance at the point (x, y, t) and L_0 is the mean luminance of the display area. In most experiments, L_0 is set to be the middle of the luminance range of the monitor. If luminance is a linear function of voltage produced by the DAC, the 8-bit DACs discussed earlier can thus produce contrasts in steps of $1/128 = 0.78\%$, i.e. they are capable of generating contrasts at $n \times 0.78\%$, $n = 0, \pm 1, \pm 2, \dots, \pm 127$. Steps of this size are too coarse for vision experiments. Human contrast sensitivity for sinusoidal grating detection and motion direction discrimination can be as high as 700 (Kelly, 1979; Burr and Ross, 1982; Lu and Sperling, 1995); thus, the contrast threshold can be as low as $1/700 = 0.15\%$. And, because the threshold refers to the peak contrast modulation of sinusoidal waves and a few (e.g. 5) contrast quantization steps are required to reasonably approximate a sinusoidal grating, contrast quantization steps less than $0.15\%/5 = 0.03\%$ are required to generate sinusoidal gratings at threshold. Another example is in studying second-order motion (Chubb and Sperling, 1988) where first-order (luminance) contamination must be removed. There has been recent development of extremely sensitive calibration procedures (Lu and Sperling, 2001) that can detect and eliminate luminance contaminations in second-order displays with 0.05% contrast. In general, contrast quantization steps less than 0.03% are desirable for monochromatic displays. This translates into a resolution of $2 \times (1/0.03\%) = 6667 = 2^{12.7}$ luminance steps, or 12.7 bits. For chromatic displays, 10–12 bits color resolution is desirable (Tiippana et al., 2000). This paper is concerned only with monochromatic display systems.

There are several ways to increase the luminance resolution. One method is to increase background luminance, L_0 in Eq. (1). Because this procedure does not change luminance quantization in the display system, it decreases the size of the minimum contrast steps and therefore increases the contrast resolution. However, it has the disadvantage of restricting the maximum contrast range.

The most popular method uses a passive resistor network to attenuate the outputs of the three DACs and re-combine the attenuated signals into one analog signal, which can be used to drive a monochrome monitor, or the green gun of a color monitor (Pelli and Zhang, 1991). In the second author's laboratory, the Pelli–Zhang video attenuators manufactured by the

Institute of Sensory Research (ISR) at Syracuse University (http://web.syr.edu/~isr/products/vid_atten.html) were capable of generating video signals with 12.5 bits of voltage resolution.

The Pelli–Zhang attenuator offers a simple and elegant way to generate high luminance resolution monochromatic white displays on monochrome monitors with white or near white phosphors, or monochromatic green displays using the green phosphors of conventional color monitors. Although high-resolution monochromatic green displays are technically acceptable in experiments only concerned with luminance modulations, most researchers and in fact subjects prefer white displays. Probably due to lack of a market, high quality monochrome monitors are very hard to find and are often very expensive. In contrast, the quality of color monitors has improved and the price has dropped. Our tests have shown that several monitors made by ViewSonic and Sony are far better than monochrome monitors (Nanao FlexScan 6600) with respect to bandwidth, pixel independence, and spatial resolution. All these characteristics are important for producing high-quality displays for vision experiments (Pelli, 1997; Brainard et al., 2002).

In this paper we describe a video switcher that modifies the outputs of conventional computer graphics cards to generate high luminance resolution monochromatic (near white) displays on color monitors. The design incorporates a modified Pelli–Zhang video attenuator to generate a single-channel high-resolution video signal from the R and B outputs of computer graphics cards. It then duplicates the same signal to drive the three RGB channels of color monitors. While the attenuator part uses a network similar to the Pelli–Zhang design, video amplifiers are used to duplicate the signal. The design includes a pushbutton that can be used to switch between a normal color mode and a high luminance-resolution monochrome mode. It also includes a trigger output that can be used to synchronize other equipment (e.g. fMRI recording) to the video signal.

2. Methods

To generate a high resolution video signal without introducing significant distortion, the video switcher must have a very high bandwidth (> 200 MHz) and must match the impedance of the computer graphics card at its input end and the impedance of the monitor at its output end—poor impedance match would result in energy reflection in the display system and therefore ghost images on the CRT (multiple spatially shifted copies of the intended video images).

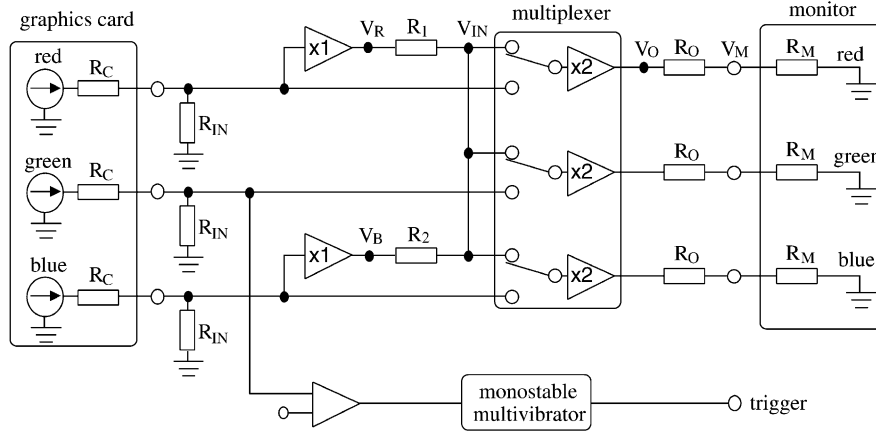

Fig. 1. The electronic circuit diagram of a video switcher. The graphics card and monitor are shown to better illustrate the connection and calculations. The inputs of the multiplexer can be switched synchronously between two modes, controlled by a pushbutton (not shown). The mode in Fig. 1 is monochromatic mode. The three input resistors ($R_{IN} = 75 \Omega$) and three output resistors ($R_O = 75 \Omega$) satisfy the impedance-match requirement of the graphics card and the monitor, respectively. The values of resistors R_1 and R_2 are calculated to achieve the desired BTRR. For example, if $R_1 = 150 \Omega$, $R_2 = 3.6 \Omega$, the BTRR is 45.5, equivalent to 13.4 bits. After being amplified and compared by a comparator, the green signal in the monochromatic mode is used to control a monostable multivibrator to generate a 5 V, 100 μ s pulse to trigger recording device. In the chromatic mode, the switcher works as if it does not exist. Ground and synch connections are not shown.

2.1. Circuit diagram and design principles

Fig. 1 is an electronic circuit diagram of a video switcher. It is shown connected to a computer graphics card at the input end and a computer monitor at the output end. The impedance of the graphics card R_C and that of the monitor R_M are shown explicitly to help illustrate the resistance calculations. To simplify the calculations, we assume that all the amplifiers are ideal operational amplifiers with infinite input impedance and zero output impedance.

There is a triple 2-to-1 multiplexer in the diagram. The multiplexer contains three amplifiers, each of which has a fixed gain of 2. The multiplexer has two working modes, controlled by a semiconductor chip with a pushbutton (not shown in the circuit diagram). When it is in the mode shown in Fig. 1, the three amplifiers receive the same input (V_{IN}), so the voltages (V_O) delivered to the three channels of the monitor are the same. Therefore displays on the monitor are monochromatic. When the multiplexer is in the other mode (opposite to what is shown in Fig. 1), the three amplifiers pass the RGB signals from the computer graphics card to the individual RGB channels of the monitor without any modification. Therefore display system functions in its “normal” color mode. The color mode is designed for normal daily use of the display system when it is not used to deliver high gray-level resolution visual stimuli. We focus on the monochrome mode in the following description.

In the monochrome mode, each amplifier of the multiplexer works as a non-inverting average (Irvine, 1981). It combines analog outputs of the red (V_R) and blue (V_B) channels of the computer graphics card with

weights determined by R_1 and R_2 . The two voltage followers—amplifiers with gain of 1—are used to isolate the signals between the computer graphics card and the averages. Like Pelli and Zhang (1991), we set $R_1 > R_2$.

$$V_{IN} = \frac{R_2}{R_1 + R_2} V_R + \frac{R_1}{R_1 + R_2} V_B \quad (2)$$

When V_R and V_B are at their maxima, V_{IN} reaches its maximum. Because $\max(V_R) = \max(V_B)$, we can derive from Eq. (2) that:

$$\max(V_{IN}) = \max(V_R) = \max(V_B). \quad (3)$$

From Eq. (2), we can also compute the blue-to-red ratio (BTRR)—the ratio of the contributions of V_B and V_R to V_{IN} :

$$\text{BTRR} = \frac{R_1}{R_1 + R_2} / \frac{R_2}{R_1 + R_2} = \frac{R_1}{R_2}. \quad (4)$$

Because $R_O = R_M$ (discussed below), we have:

$$V_O = 2V_M. \quad (5)$$

Since each amplifier inside the multiplexer has a gain of 2, we know $V_O = 2V_{IN}$. Considering Eq. (5), we deduce that

$$V_M = V_{IN} \quad (6)$$

From Eqs. (3) and (6), we conclude that the output of the video switcher has the same dynamic range as the output of computer graphics card, so the switcher can drive the monitor in its full dynamic range.

Furthermore, from Eqs. (2), (4) and (6), we can get the relation between the input and output:

$$V_M = V_{IN} = \frac{1}{BTRR + 1} V_R + \frac{BTRR}{BTRR + 1} V_B. \quad (7)$$

Therefore, the video switcher reduces video voltage steps by a factor of $(BTRR + 1)$ without altering the voltage dynamic range. As a result, it increases voltage resolution by the same factor. For example, a BTRR of 31 increases the voltage resolution from 256 levels to $(31 + 1) \times 256 = 8192$ levels.

The resistance values of R_{IN} and R_O are set to match the output impedance of the computer graphics card and the input impedance of the monitor:

$$R_{IN} = R_C, \quad R_O = R_M, \quad (8)$$

both of which are normally at 75Ω .

The resistance values of R_1 and R_2 are taken to achieve the desired BTRR (Eq. (4)). Theoretically, lower resistor values lead to better temporal frequency response. However, the values must be high enough to limit the output current of the voltage followers.

The green-channel of the computer graphics card is not used for visual stimulus in the monochromatic mode. It is used to control a trigger (5 V, 100 μ s) which can be used to communicate with other equipment. This is implemented with a comparator and a monostable multivibrator.

Other signals from the computer graphics card, such as horizontal and vertical syncs, and monitor ID, go through the video switcher without any change.

2.2. Selecting appropriate components

The quality of the video signal at the output of the video switcher depends critically on the quality of the electronic components. We discuss them in turn:

- 1) Both the voltage followers and the multiplexer must have high bandwidth (≥ 200 MHz), high slew rate (≥ 500 V/ μ s), high input impedance (≥ 1 M Ω), and low output impedance ($\leq 1 \Omega$). High bandwidth is necessary to ensure accurate transmission of the video signal. 200 MHz is used here because most of the high quality monitors have bandwidth ≤ 200 MHz. Our recommendations of voltage follower and multiplexer are AD8074 and AD8185, respectively, from Analog Devices of USA (<http://www.analog.com>).
- 2) In order to minimize chromatic error in the monochromatic mode, the three output resistors (R_O in Fig. 1) must have almost the same values (variation $\leq \pm 0.1\%$). In addition, the three amplifiers in the multiplexer must have low differential gain error ($\leq 0.1\%$).
- 3) To ensure impedance match, the input and output resistors should have precision of 1% or better. To achieve high signal stability, all resistors must have

a temperature coefficient of ± 100 PPM/ $^\circ$ C or better.

- 4) To reduce interference from the environment, the entire switcher should be enclosed in a grounded metal box.
- 5) High quality fully shielded video cables with high quality VGA connectors are also essential. In our experience, even a short unshielded segment can cause severe signal distortions.

2.3. Measuring actual BTRR

The actual BTRR of a video switcher may be different from the designed value due to (1) the deviation of the actual resistance of R_1 , R_2 and R_{IN} from the theoretical design, (2) non-zero output impedance of the voltage followers that makes the actual BTRR lower than the designed BTRR, (3) finite input impedance of the amplifiers which makes the actual BTRR lower than the designed, and (4) differential error of the blue and red outputs of computer graphics cards. Before a video switcher can be used in an experiment, the actual BTRR must be measured. We describe a method based on human visual psychophysics. This method has been used in the second author's laboratory since 1996. A different version, based on the same principle, was described by Colombo and Derrington (2001). We will describe another method using electronic equipment later in this paper.

In this method, a horizontal square-wave grating is generated on a monitor connected to a computer via a video switcher in its monochrome mode. The grating has two different types of pixels in alternating bands. One type of pixels has RGB values of $[0, 0, b]$, and the other $[r, 0, b - \Delta b]$ (Fig. 2). The observer adjusts the value r to find the critical r_c that makes the alternating bands indistinguishable. BTRR can be calculated by the

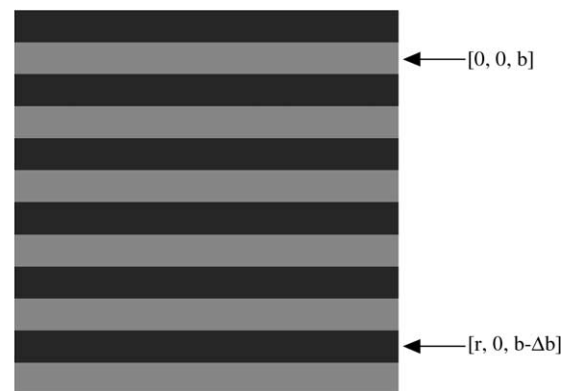

Fig. 2. The grating used in measuring the BTRR of a video switcher. Two types of pixels of the grating have RGB values of $[0, 0, b]$ and $[r, 0, b - \Delta b]$, where b is normally set to be 180, Δb is around 5 for $BTRR < 50$. In monochromatic mode, the observer adjusts r to find a critical r_c , at which the grating is invisible. The BTRR can be computed using Eq. (9).

formula:

$$\text{BTRR} = r_c / \Delta b \quad (9)$$

To achieve the best accuracy in estimating BTRR with the above method, several points are worth noting. First, Δb should be as large as possible. Second, the observer should move back and forth from the monitor to use the most sensitive part of his or her contrast sensitivity during the calibration process. Third, since the grating is perceived to be uniform within a range of r values, we can measure two r_c values at which the grating is just visible. One measurement is made when the bands of $[r, 0, b - \Delta b]$ are dimmer than those of $[0, 0, b]$ and the other is made when the bands of $[r, 0, b - \Delta b]$ are brighter than those of $[0, 0, b]$. The average of the two r_c values shall be used in Eq. (9). In principle, the b value is not critical because BTRR is a constant across the whole voltage range (shown in Section 3.2). In practice, b is usually set to be 180, which corresponds to the middle of the luminance dynamic range of a CRT with a display gamma of 2.

2.4. Using the video switcher to achieve high gray-level resolution

To display pixels with a specified contrast on a monitor, one needs to first measure the non-linear relationship between pixel gray level (U) specified by the computer graphics card and output luminance on the monitor with a procedure normally called “gamma correction”. For most monitors and 8-bit graphics cards, the relationship can be described as:

$$L(U) = L_{\min} + (L_{\max} - L_{\min})(U/255)^\gamma, \quad (10)$$

where L_{\max} , L_{\min} and γ are determined with a gamma correction procedure, either by using photometers or by a combination of psychophysical procedures and photometric measurements (Lu and Sperling, 1999).

If we set background luminance $L_0 = (L_{\max} + L_{\min})/2$, the relationship between pixel contrast $c(U)$ and pixel gray level U is:

$$c(U) = \frac{L(U) - L_0}{L_0} = \frac{L_{\max} - L_{\min}}{L_{\max} + L_{\min}} (U/255)^\gamma. \quad (11)$$

We can rewrite Eq. (11) to solve for the required gray level for a given contrast:

$$U = 255 \times \left(\frac{L_{\max} + L_{\min}}{L_{\max} - L_{\min}} \times c \right)^{1/\gamma}, \quad (12)$$

where U is normally a non-integer number.

In the monochromatic mode, the blue (b) and red (r) are calculated from U and BTRR based on Eq. (7):

$$b = \min \left[\text{floor} \left(\frac{\text{BTRR} + 1}{\text{BTRR}} U \right), 255 \right], \quad (13)$$

$$r = \text{round} \left[\left(U - \frac{\text{BTRR}}{\text{BTRR} + 1} b \right) (\text{BTRR} + 1) \right], \quad (14)$$

where the function “min” returns the minimum of the two input numbers, the function “floor” returns the closest integer less than or equal to its input, and the function “round” returns the closest integer to its input.

Whereas gamma functions (Eq. (10)) provide good approximations of the non-linear functional relationship between input voltage and output luminance of monitors and have been described here for subsequent analytical discussions in this paper, people have used non-parametric linear interpolation methods to achieve better results in performing gamma corrections (Lu and Sperling, 1995). Specifically, pairs of input voltage and output luminance are tabled over the full dynamic range of a monitor. The required gray level U for a given luminance is then calculated using linear interpolation based on the data in the table. We describe in somewhat detail a procedure suggested by Brainard et al. (2002) in relation to the video switcher.

In this procedure, we first measure the luminance, $\text{Lum}(b)$, generated by assigning $[0, 0, b]$ to a display region, for $b = 0, 1, \dots, 255$. Accurate measurements of $\text{Lum}(b)$ can be achieved using averages of digitized outputs from photometric measurements. Because $\text{Lum}(b)$ is monotonic, for a given luminance L , we define b as the index of $\text{Lum}(b)$ that satisfies:

$$\text{Lum}(b) \leq L < \text{Lum}(b + 1). \quad (15)$$

Within a small luminance range, $\text{Lum}(b)$ to $\text{Lum}(b + 1)$, the voltage and luminance are approximately linearly related. We can use linear interpolation to calculate the required red value (r) in generating L :

$$r = \text{round} \left[\left(\frac{L - \text{Lum}(b)}{\text{Lum}(b + 1) - \text{Lum}(b)} \text{BTRR} \right) \right]. \quad (16)$$

Aside from correcting display non-linearities of monitors, the use of the video switcher with the gamma-correction procedure also greatly reduces the impact of the static errors of the DACs on display contrast when b keeps unchanged. Most DACs are guaranteed to be monotonic with one-step accuracy—the voltage generated by a DAC is only accurate within one-step of the claimed resolution (e.g. 1/256 of the full voltage dynamic range for an 8-bit DAC). The discrepancy between the actual voltage generated by a DAC and the corresponding theoretical value is called “one-step error” (Pelli and Zhang, 1991). Using a video switcher and assuming the result from the calibration procedure described above is perfect, the static error of the display system may be reduced by a factor of $(\text{BTRR} + 1)$ —the large static errors in the output of the blue DAC are corrected by the use of attenuated red DAC outputs, to the order of $1/(\text{BTRR} + 1)$ of the original step size.

2.5. Generating a trigger output

The green output of the computer graphics card is not used in generating high gray-level resolution images. Instead, it is used to control the trigger output. In the monochromatic mode, when the level of the green channel changes to 255, the BNC port of the video switcher sends out a standard trigger signal. To synchronize the trigger with any particular display region of a monitor, the trigger should be controlled by turning on the green output of the graphics card in the corresponding region.

3. Testing

We tested several video switchers. Because all the results are essentially the same, we report the results from one of them.

3.1. Test 1: BTRR

We measured the actual BTRR using the visual psychophysics procedure described earlier. Three observers, with normal or corrected-to-normal vision, performed the procedure 18 times. Mean BTRR was 38.5 with a standard deviation (S.D.) of 0.3.

To verify the psychophysical results, we also measured the BTRR using a similar procedure in which observers compared the voltage of the two types of pixels on an oscilloscope. Observers performed the procedure ten times. Mean BTRR was 38.6 with a S.D. of 0.4.

Measured BTRR was virtually identical using the two procedures ($t = 0.75$, $P > 0.46$). This suggests that the simple psychophysical procedure is quite reliable. The actual BTRR is about 13% lower than the calculated using Eq. (4). As discussed in Section 2.3, the actual BTRR was expected to be lower than the theoretical prediction because the assumptions used in our theoretical calculations were only approximate.

3.2. Test 2: linearity

We also tested linearity of the video switcher using a data acquisition system, an acquisition board (National Instruments, USA) controlled by the IGOR program (WaveMetrics Inc., USA). Due to the sampling rate limitation of the acquisition system, we used the DAC outputs from the acquisition board as the inputs to the video switcher instead of the outputs of a computer graphics card. The testing circuit is shown in Fig. 3.

The linearity test was done in three steps. First, we measured V_M as a function of V_B at different V_R levels. Second, we measured V_M as a function of V_R at different V_B levels. Third, we compared V_M with the

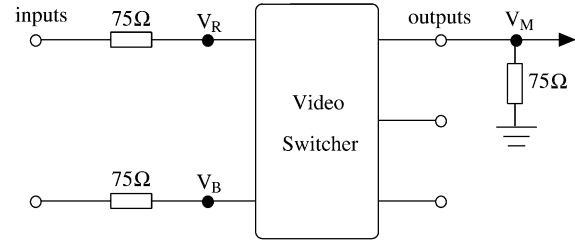

Fig. 3. The diagram of a circuit used in testing the linearity of the video switcher. In monochromatic mode, two DAC outputs from the acquisition board were used to simulate the blue and red inputs to the switcher. Since the output impedance of the DACs is close to zero, two 75- Ω resistors are connected to simulate the output resistors of the graphics card. One of three output channels was monitored by the acquisition system. Sampling rate was 200 kHz. The resolution of DACs and ADC of the acquisition board was 16-bit. Note that the applied voltages by the acquisition board DACs were twice of V_R or V_B .

expected V_M calculated for the various combinations of V_R and V_B .

Fig. 4A shows V_M as a function of V_B at three V_R levels, $V_R = 0$, 0.35 and 0.7 V (0.7 V is the maximum V_R). Linear regression lines were fitted to all three functions. In all three cases, the correlation between V_M and V_B approximated 1 ($\text{Pr} \geq 0.99999996$). In addition, the slopes of the three regression lines were essentially the same (ranging from 0.98483 to 0.98486). This confirms the deduction from Eq. (7) that V_M is a linear function of V_B with a slope independent of V_R .

V_M as a function of V_R was measured at eight V_B levels (0–0.7 V with increment of 0.1 V). Fig. 4B shows the function at three V_B levels. Again, linear regression lines were fitted to all the functions and, again, the correlation between V_M and V_R approximated 1 (≥ 0.9999994). In addition, the slopes of the eight regression lines were essentially the same (ranging from 0.02376 to 0.02391). This confirms the deduction from Eq. (7) that V_M is a linear function of V_R with a slope independent of V_B .

Fig. 4C shows V_M as a function of V_R and V_B combined. Again, a linear regression was fitted to the data. Again, the correlation between V_M and summation of V_R and V_B approximated 1 (≥ 0.9999998). The slope of the regression line was 1.008, which is close to the theoretical slope of 1. We conclude that the switcher generated desired V_M by combining V_R and V_B linearly.

3.3. Test 3: Bandwidth

We performed some basic bandwidth measurements on the video switcher with a spectrum analyzer (Agilent 70004A, 100 Hz–26.5 GHz). We also compared the pixel waveform at the output of the computer graphics card with the pixel waveform at the output of the video switcher, after the signal had passed through the switcher.

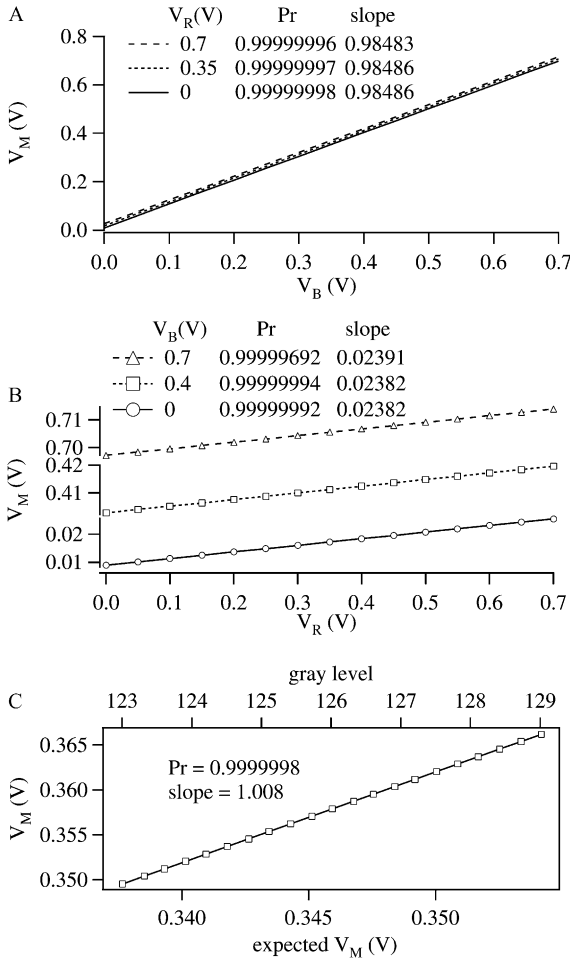

Fig. 4. Linearity of the video switcher. Measurements were performed with an acquisition system using the diagram in Fig. 3. (A) V_M as a function of V_B at three V_R levels. (B) V_M as a function of V_R at three V_B levels. (C) V_M as a function of combined input of V_B and V_R , to simulate the gray level from 123 to 129 (top axis) with increment of 0.3. The bottom axis is the calculated input voltage (Eq. (7)).

The switcher’s -3 dB bandwidth is around 230 MHz (1.4 V p-p), which is higher than the bandwidth of most high quality monitors (~ 200 MHz).

Fig. 5 shows the waveforms at the output of the computer graphics card and at the output of the video switcher, taken from a high-speed oscilloscope (Tektronics TDS7104, 10 Gs/s). The pulse has an amplitude of 0.7 V. The waveforms from the graphics card and from the video switcher are almost the same, except for the fact that the rise and fall time is a little slower after they have passed through the video switcher.

3.4. Test 4: accuracy of contrast

Tests 2 and 3 confirmed the electrical fidelity of the video switcher. We examined the accuracy of the video-switcher display system in presenting contrast in this test. The luminance table for the blue DAC, Lum (b), was measured using the photometer and data acquisi-

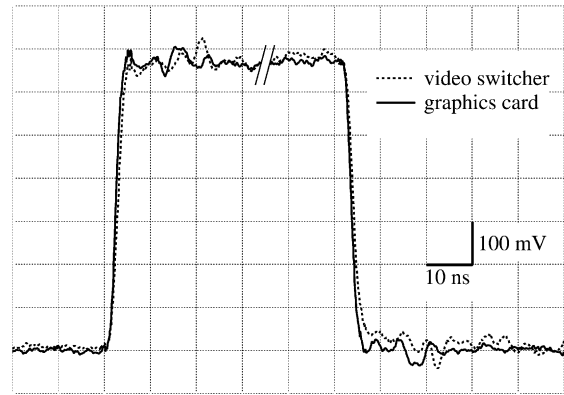

Fig. 5. Comparison of the waveforms of a video signal, measured at the output of the computer graphics card, and at the output of the video switcher. The test signals had maximum amplitude of 0.7 V. The measurement was done on an oscilloscope. The waveforms with and without the switcher are virtually identical.

tion system used in Test 2. A pair of luminance levels, symmetric to the mean luminance, was used to achieve a given nominal contrast. The corresponding $[r, 0, b]$ for each luminance level was calculated using Eqs. (15) and (16) and assigned to a luminance patch in alternation on the CRT monitor. We then measured the luminance of the patch in real time to determine the “real” contrast. For contrasts lower than 3.2%, we kept the blue DAC constant ($b = 189$) and changed only the red DAC. Fig. 6 plots the difference between the measured and nominal contrasts over the full contrast range.

From the functional relationship between gray-level U assigned to the DACs and monitor luminance (Eq. (11)), we can theoretically derive the expected contrast errors $\epsilon_{\Delta C}$ due to the static errors $\epsilon_{\Delta U}$ of the DACs. Differentiating Eq. (11), we have:

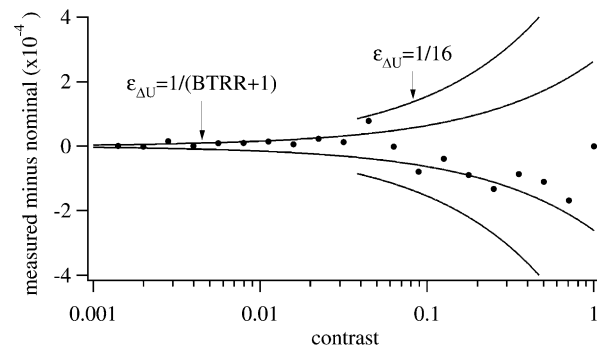

Fig. 6. Contrast error (measured contrast minus nominal contrast) as a function of contrast for a video-switcher display system, measured at twenty contrast levels. For each point, integer number of display frames was digitized from the analog output of a photometer using a 16-bit ADC (sampling rate: 10 kHz). To improve the accuracy of measurement, we repeated the measurements 100 and 20 times for the contrasts lower and higher than 3.2% respectively. The S.D. of the measured contrast range from 0.00015 to 0.00019 across the whole contrast range. The curves show the theoretical ranges of contrast errors for different effective DAC errors, $\epsilon_{\Delta U} = 1/(BTRR + 1)$ and $1/16$ (Eq. (17) when $L_{min} = 0$).

$$\varepsilon_{\Delta c} = \varepsilon_{\Delta U} \times \frac{dc}{dU} = \frac{L_{\max} - L_{\min}}{L_{\max} + L_{\min}} \frac{\gamma \times c^{\gamma-1}}{255} \varepsilon_{\Delta U}. \quad (17)$$

In low contrasts (< 3.2%), b was held constant. So $\varepsilon_{\Delta U}$ is completely determined by the static errors produced by the red DAC of the graphics card, which is reduced from 1 to $1/(\text{BTRR}+1)$ using the video switcher. With $\text{BTRR} = 38.5$ and $\gamma = 2.6$, we expect that measured contrast error lies within $\pm \varepsilon_{\Delta c}$ when $\varepsilon_{\Delta U}$ is $1/(\text{BTRR}+1)$. Our result confirmed this except that one point (at contrast 0.0028) is slightly out of the range (Fig. 6). The root mean square contrast error is 1.2×10^{-5} (or 0.0012%) in this contrast range.

In higher contrasts, both b and r were varied to produce display luminance. Static errors of both blue and red DACs contribute to contrast errors. As discussed in Section 2.4, if the calibration for luminance table were perfect, the static errors of the blue DAC [$\text{BTRR}/(\text{BTRR}+1)$] would be “corrected” and replaced by the smaller effective static errors of the red DAC [$1/(\text{BTRR}+1)$] with the use of the video switcher. However, in practice, the calibration is not perfect. In order to gauge the impact of static errors of the DACs on contrast errors, we superimpose two pairs of theoretical $\varepsilon_{\Delta c}$ versus contrast functions [Eq. (17) when $\varepsilon_{\Delta U} = 1/(\text{BTRR}+1)$ and $1/16$] on the measured contrast errors in Fig. 6. As can be seen from the figure, almost all the measured contrast errors fall on or between the $\varepsilon_{\Delta U} = 1/(\text{BTRR}+1)$ curves. The root mean square contrast error is 7.3×10^{-5} (or 0.0073%) in this contrast range. The result indicates that we have effectively reduced the impact of DAC one-step error by a factor of about $(\text{BTRR}+1)$ but at least 16.

3.5. Test 5: timing of the trigger signal

A photodiode, which responds very quickly to luminance changes, was attached to a Sony CPD-G220 monitor. Its output was recorded by the acquisition system, triggered by the signal from the video switcher. Repeated recordings indicated that the photodiode response and the trigger were synchronized within 0.3 ms.

4. Discussion

The video switcher provides a compact, inexpensive, and easy-to-use way to generate high luminance resolution displays using conventional computer graphics cards and color monitors. It is simply connected between the analog outputs of the graphics card and the monitor. It can also switch between a monochromatic mode and a chromatic mode, providing additional convenience. In addition, the trigger channel allows

researchers to synchronize other equipment to the visual displays.

The video switcher is designed to drive a color monitor. However, it can drive a monochrome monitor without any modification. Although the unit is designed primarily for vision experiments, it can also be used in medical (e.g. X-ray, MRI, and CT displays) and military (e.g. Radar, night scene displays) settings where high luminance resolution displays are desirable.

4.1. Considerations in selecting BTRR

Theoretically, the video attenuator for monochrome monitors designed by Pelli and Zhang (1991) and the video switcher described here are capable of generating 16 bits of voltage resolution. However, many factors, such as the gamma nonlinearity of monitors and inaccuracy of the graphics card DACs, constrain the number of achievable bits. On the other hand, large BTRRs require large values for R_1 in Fig. 1 (Eq. (4)), which may decrease the bandwidth of the device. As discussed in Section 1, a 12.7-bit luminance resolution is adequate for most vision experiments.

The BTRR of the video switcher determines the increased voltage resolution. Due to the non-linear relationship between voltage and luminance (Eq. (10)), the actual luminance resolution will be higher or lower than the voltage resolution, depending on the gray level (U).

From Eq. (7), we know the minimum gray level step $\Delta U = 1/(\text{BTRR}+1)$. By differentiating Eq. (10), we can compute the minimum luminance step:

$$\Delta L = \Delta U \times \frac{dL}{dU} = \frac{(L_{\max} - L_{\min}) \times \gamma \times U^{\gamma-1}}{(\text{BTRR} + 1) \times 255^{\gamma}}. \quad (18)$$

So the number of the luminance levels is

$$\frac{L_{\max}}{\Delta L} = \frac{L_{\max}}{L_{\max} - L_{\min}} \times \frac{(\text{BTRR} + 1) \times 255^{\gamma}}{\gamma \times U^{\gamma-1}}. \quad (19)$$

For most CRT monitors, gamma is about 2–3. Fig. 7 shows luminance step as a function of gray level U (Eq. (18)) at several gamma values when $\text{BTRR} = 38.5$. If the full dynamic range of a monitor is used, then the number of luminance levels is determined by the maximum ΔL , which is achieved when $U = 255$. For $\text{BTRR} = 38.5$ and $L_{\min} = 0$ (dark background), the luminance resolution at this point is 12.3–11.7 bits for gamma of 2–3 (Eq. (19)). For experiments that use only low contrasts (< 5%) around the middle luminance dynamic range of a monitor, the number of luminance levels can be calculated from Eq. (19) when $L(U) = (L_{\max} + L_{\min})/2$. For $\text{BTRR} = 38.5$, the luminance resolution at this point is 12.8–12.4 for gamma of 2–3.

Considering gamma non-linearity of CRT monitors, we recommend a BTRR between 31 and 63 for most

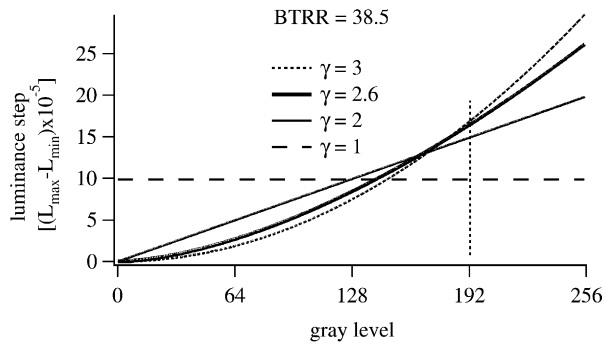

Fig. 7. Luminance step size as a function of gray level U for several display gammas. The horizontal broken line indicates the constant luminance step size when the luminance is proportional to voltage ($\gamma = 1$). Most CRT monitors have γ value from 2 to 3. The bold curve shows the step size for the monitor we measured on ($\gamma = 2.6$). At the middle luminance level of this monitor (vertical dotted line), the luminance step size results in a 12.6 bit luminance resolution.

display systems. This is close to the BTRR (≈ 24) used in the Pelli–Zhang video attenuator produced by ISR at the Syracuse University.

4.2. Inaccuracies of graphics card DACs

When using computer system to achieve lower contrast, one should keep in mind that the DACs in the graphics card have one-step errors and consider whether it is acceptable for experiment. The video switcher provides a method to increase the voltage resolution of DACs. But the ultimate contrast resolution of the display system is also limited by the inaccuracies of the graphics DACs, consisting of both random fluctuations and static errors. The impact of random fluctuations is greatly reduced by the temporal integration naturally occurring in the phosphors of CRT monitors. The static errors are of primary concern in accurately presenting contrasts in a display system. To reduce the impact of static errors, Pelli and Zhang (1991) combined all three DACs of a graphics card with different weights. We have chosen to use only two DACs to achieve high gray-level resolution in the design of the video switcher to simplify its design and usage (e.g. programming of a video-switcher display system). In low contrast achieved by changing only the red DAC, it is reasonable to assume that the video switcher reduces the static errors of the display system from $1/256$ of the full voltage dynamic range to $1/[256 \times (\text{BTRR} + 1)]$. For higher contrast, we have shown that, using the video switcher together with the calibration procedure, we can reduce the static errors of the display system from $1/256$ to at most $1/(256 \times 16)$ of the full voltage dynamic range of the system. The accuracy of display is comparable with the specified gray level resolution of the video switcher system, and is in fact higher than the accuracy achieved by Pelli and Zhang (1991) in the high contrast range.

4.3. BITS++: another method to achieve high chromatic resolution

As we were preparing this manuscript, we learned that Cambridge Research Systems Ltd. has just developed a new “BITS++” technology that increases the color resolution of Digital Visual Interface (DVI) computer graphics cards from 8 to 14 bits per RGB channel. The BITS++ technology not only solved the luminance resolution problem for monochrome displays but also the color resolution problem for chromatic displays. The method described here can be viewed as a simple and inexpensive supplement to BITS++ for monochrome display systems.

4.4. Chromaticity of monochromatic displays generated by video switchers

The video switcher is designed to generate high luminance resolution monochromatic displays on conventional color monitors by driving their RGB channels with identical voltages. For most color monitors, the display is almost pure white when all three RGB channels receive the same voltage. On some good color monitors, one can adjust the color temperature of the display to achieve pure white when the three RGB channels receive the same voltage signals.

A potential source of chromaticity distortion is the differences among the actual RGB voltage signals produced by video switchers because of differences between the output resistors (R_O) and differential gains between different channels of the multiplexers. Normally, the gain difference between the three channels of a multiplexer is very small (0.01% for the multiplexer we used), so the voltage difference to the three channels is mostly due to variations in the output resistors. When the resistor values are within 0.1%, the chromaticity distortion is below the human detection threshold.

5. Conclusions

The video switcher can be used to generate high luminance resolution monochrome visual displays with conventional 8-bit per channel computer graphics cards and analog color monitors over the entire luminance dynamic range of the monitors. Users can also conveniently switch between the normal color display mode and high luminance resolution mode. The switcher can generate a trigger pulse to accurately synchronize the recording device with the actual visual display.

Acknowledgements

This research was supported by research grant No. 30128006 from the National Natural Science Foundation of China and a fellowship from the WKC Education Foundation of Hong Kong to ZLL. The authors thank Litong Equipment Co. Ltd. (Suzhou, China) for making the video switchers and Yongsheng Bai, Lingfang Kong and Haiyang Wei for helpful discussions. We also thank Gary Thorne and Debbie Dao for their excellent comments on an earlier version of the manuscript.

References

- Brainard DH, Pelli DG, Robson T. Display Characterization. Encyclopedia of Imaging Science and Technology. New York: Wiley, 2002:172–88.
- Burr DC, Ross J. Contrast sensitivity at high velocities. *Vis Res* 1982;22:479–84.
- Chubb C, Sperling G. Drift-balanced random stimuli: a general basis for studying non-Fourier motion perception. *J Opt Soc Am A* 1988;5:1986–2007.
- Colombo E, Derrington A. Visual calibration of CRT monitors. *Displays* 2001;22:87–95.
- Hood DC, Finkelstein MA. Sensitivity to light. In: Boff KR, Kaufman L, Thomas JP, editors. Handbook of Perception and Human Performance (Chapter 5). New York: Wiley, 1986:1 (Chapter 5).
- Irvine RG. Operational Amplifier Characteristics and Applications. Englewood Cliffs, NJ: Prentice-Hall, 1981:55–60.
- Kelly DH. Motion and vision. II. Stabilized spatio-temporal threshold surface. *J Opt Soc Am* 1979;69:1340–9.
- Lu ZL, Sperling G. The functional architecture of human visual motion perception. *Vis Res* 1995;35:2697–722.
- Lu ZL, Sperling G. Second-order reversed phi. *Perception Psychophys* 1999;61:1075–88.
- Lu ZL, Sperling G. Sensitive calibration and measurement procedures based on the amplification principle in motion perception. *Vis Res* 2001;41:2355–74.
- Pelli DG. Pixel independence: measuring spatial interactions on a CRT display. *Spatial Vis* 1997;10:443–6.
- Pelli DG, Zhang L. Accurate control of contrast on microcomputer displays. *Vis Res* 1991;31:1337–50.
- Tiippana K, Rovamo J, Näsänen R, Whitaker D, Mäkelä P. Contrast matching across spatial frequencies for isoluminant chromatic gratings. *Vis Res* 2000;40:2159–65.