

Enhanced antitumor effect against human telomerase reverse transcriptase (hTERT) by vaccination with chemotactic-hTERT gene-modified tumor cell and the combination with anti-4-1BB monoclonal antibodies

Xiaoyan Lin¹, Chunxia Zhou¹, Shengdian Wang², Dongmei Wang¹, Wenbo Ma¹, Xiao Liang³, Chen Lin³, Zheng Wang³, Jie Li¹, Sujuan Guo¹, Youhui Zhang¹ and Shuren Zhang^{1*}

¹Department of Immunology, Cancer Institute, Peking Union Medical College and Chinese Academy of Medical Sciences, Beijing, People's Republic of China

²Center of infection and immunity, Institute of Biophysics, Chinese Academy of Sciences, Beijing, People's Republic of China

³State Key Laboratory of Molecular Oncology, Cancer Institute, Peking Union Medical College and Chinese Academy of Medical Sciences, Beijing, People's Republic of China

Human telomerase reverse transcriptase (hTERT) represents an attractive target for cancer immunotherapy because hTERT is reactivated in most human tumors. In an attempt to develop an effective vaccine against most human cancers, we constructed chemotactic-hTERT vaccine. Two hTERT fragments encoding multiple cytotoxic T lymphocyte and T helper cell epitopes were fused as a tumor antigen (named Te). The plasmid based DNA vaccine (pCCL21-Te-Fc) was constructed by linking human CCL21 and IgG Fc gene sequences to each end of Te. In poorly immunogenic B16F10 mouse melanoma model, DNA (pCCL21-Te-Fc) vaccination significantly inhibited tumor growth and all of the mice were dead by day 52. The immunization with pCCL21-Te-Fc-modified tumor cells (B16/CCL21-Te-Fc) resulted in a higher antitumor effect than DNA vaccination and 25% of tumor-bearing mice achieved long-term survival (>120 days). The combined therapy of B16/CCL21-Te-Fc plus anti-4-1BB MAbs further enhanced the immune response, resulting in 75% of tumor-bearing mice achieved long-term survival (>120 days) in subcutaneous model and few lung nodules in pulmonary metastasis model. Rechallenge experiment showed that a persistent memory response was successfully induced by the combined therapy. *In vivo* depletion of lymphocytes indicated that CD8⁺ T cells were essential in the antitumor activity induced by B16/CCL21-Te-Fc plus anti-4-1BB MAbs, whereas NK cells and CD4⁺ T cells played substantial roles. The CTL activity induced by pCCL21-Te-Fc-transfected PBMCs specifically lysed a variety of human leukocyte antigen-matched and hTERT-positive human tumor cells, suggesting pCCL21-Te-Fc could serve as a vaccine against most human cancers.

© 2006 Wiley-Liss, Inc.

Key words: hTERT; immunotherapy; chemotactic-hTERT; modified tumor cell; 4-1BB

Tumor associated antigens (TAAs) are candidate targets for T-cell mediated destruction of tumor cells.¹ Although the discovery of human TAAs has revitalized efforts to develop antigen-specific vaccines and adoptive T-cell immunotherapy, most antigens (Ags) display tissue-specific expression and thus can be used only against defined malignancies. Human telomerase reverse transcriptase (hTERT) is highly expressed in >85% of human cancers derived from various histological origins, whereas its expression in normal adult tissues is extremely limited.² In addition, the risk of Ag escape by genetically instable tumors may be reduced when targeting hTERT Ag in a vaccination setting because hTERT activity is essential for maintaining the proliferation capacity of tumor cells.³ Therefore, hTERT may represent a better target against a broad range of tumors than other self-Ags such as MART-1, NY-ESO-1, gp100 and proteins of the MAGE family.⁴ Recent analyses on the immunogenicity of hTERT have convincingly shown its capability to activate tumor-specific T cells in healthy donors and cancer patients.^{3,5,6} Dendritic cells (DCs) pulsed with the human leukocyte antigen (HLA)-A2-restricted hTERT peptide 540–548 stimulated specific CTL responses in advanced cancer patients, but the antitumor effect was limited.⁶ Several ways have been proposed to improve the potency of hTERT-based vaccine, such as the utilization of major histocompatibility complex

(MHC) class I restricted hTERT peptides in combination with T helper cell (Th) epitopes to activate both CD4⁺ and CD8⁺ lymphocytes,⁷ DCs transfected with chimeric hTERT transcripts containing the lysosomal targeting signal of lysosome-associated membrane protein-1 to direct hTERT Ag processing into the class II pathway.³

Evidences are accumulating that chemokines play an integral role in the initiation of a specific immune response, so one of the strategies to improve the hTERT-based vaccine potency is to link hTERT with chemokine. The secondary lymphoid tissue chemokine/CC chemokine ligand 21 (CCL21) found on high endothelial venules and within the T-cell zones of both spleen and lymph nodes is a chemotactic factor for DCs, naive T cells, B cells as well as NK cells.^{8–11} Thus it may increase the probability of the colocalization of an antigen presenting DC with its cognate T cells, and facilitate activation and priming of immune responses. Moreover, it has the function of costimulating expansion of CD4⁺ and CD8⁺ T cells and inducing Th1 polarization.¹² Investigations have shown that CCL21 could increase the number of infiltrating T cells and mediate delayed tumor growth in animal models.^{10,12}

Another promising strategy to improve the vaccine potency is to link hTERT with IgG Fc. DCs express the receptors for the Fc portion of IgG (FcγRs), which mediate internalization of Ag–IgG complexes and promote efficient MHC-restricted Ag presentation. This process is 1,000–10,000-fold more efficient than pinocytosis.^{13,14} The interaction of Fc with FcγRs also activates DCs by upregulating surface molecules and cytokines involved in Ag presentation.^{13–15} Our previous study suggested the incorporation of the IgG Fc fragment into the tumor vaccine enhanced the immunogenicity.¹⁶

In adoptive immunotherapy, the outcome of therapy is related not only to the number of effector T cells transferred but also to the length of time the transferred T cells survive *in vivo*. Therefore, any conjunctive regimen of treatment that will promote *in vivo* expansion and survival of the specific T cells will likely improve therapeutic efficacy. As a member of the tumor necrosis factor receptor superfamily, 4-1BB is expressed on the surface of activated T cells,¹⁷ NK cells,¹⁸ monocytes¹⁹ and DCs.²⁰ Anti-4-

Abbreviations: Ags, antigens; CCL21, CC chemokine ligand 21; CTL, cytotoxic T lymphocyte; CXCR3, CXC chemokine receptor 3; DCs, dendritic cells; FcγRs, Fc receptors specific for IgG; HLA, human leukocyte antigen; hTERT, human telomerase reverse transcriptase; LPS, Lipopolysaccharide; MAbs, monoclonal antibodies; MHC, major histocompatibility complex; PBMCs, peripheral blood mononuclear cells; TAAs, tumor associated antigens; Th, T helper cells.

Grant sponsor: The Chinese Government; Grant number: 2001AA217101.
*Correspondence to: Department of Immunology, Cancer Institute, Peking Union Medical College and Chinese Academy of Medical Sciences, Beijing, People's Republic of China. Fax: +8610-67764138.
E-mail: biotherapy@caca.sina.net

Received 20 October 2005; Accepted 21 March 2006
DOI 10.1002/ijc.22048

Published online 17 May 2006 in Wiley InterScience (www.interscience.wiley.com).

1BB monoclonal antibodies (MAbs) can stimulate the proliferation of antigen-activated CD8⁺ T lymphocytes, and increase the CTL activity and production of the cytokines of the Th1 type.¹⁷ Most important is that 4-1BB signaling can inhibit activation-induced T-cell death.²¹ It is apparent that anti-4-1BB administration could provide potent *in vivo* costimulation of cellular immune responses and might be a useful immune adjuvant to costimulate T-cell mediated antitumor immune response.

In this study, we investigated whether CCL21 and IgG Fc could cooperatively enhance the potency of hTERT-based vaccine and evaluated the immune responses induced by DNA vaccine and modified tumor cell vaccine. Given the potential benefit of anti-4-1BB MAbs in enhancing the immune response, we also tested the effect of this costimulatory signal in combination with the modified tumor cell vaccine. Our results demonstrated that CCL21 and Fc synergistically enhanced the immunogenicity of hTERT-based vaccine. The immune response induced by the modified tumor cells immunization was more effective than that induced by DNA vaccination. Moreover, there was an additive effect from combining modified tumor cell vaccine with anti-4-1BB MAbs, which resulted in significant tumor delay in animal model.

Material and methods

Cell lines

Mouse melanoma cell line B16F10 (B16) was kindly provided by Dr. L.P. Chen (The Johns Hopkins University School of Medicine, Baltimore, MD). Among the human tumor cell lines used, MCF-7 (breast cancer, HLA-A*0201⁺ hTERT⁺) was provided by Dr. X.Y. Qiu (Peking University, Beijing, People’s Republic of China); SK-BR3 (breast cancer, HLA-A*0201⁻ hTERT⁺), SK-OV-3 (ovarian cancer, HLA-A*0201⁺ hTERT⁺), LNCap (prostate cancer’HLA-A*0201⁺ hTERT⁺) and PC-3M (prostate cancer, HLA-A*0201⁻ hTERT⁺) were also kindly provided by Dr. L.P. Chen; U2OS (osteosarcoma, HLA-A*0201⁺ hTERT⁻) was obtained from the type culture collection of Chinese Academy of Medical Sciences; and the TAP1/2 mutant T2 cell was a gift from Dr. W.F. Chen (Peking University, Beijing, People’s Republic of China). All cell lines were cultured in RPMI 1640 medium (Gibco-BRL) supplemented with 10% FCS (heat-inactivated, complete medium).

Plasmid constructs

pcDNA3f was derived from pcDNA3.1 (Invitrogen Life Technologies, Carlsbad, CA), in which the multiple cloning sites were altered. pcDNA3f-sig and pcDNA3f-sig-Fc containing the signal sequence of human CCL21 (abbreviated as sig) were constructed as previously described.¹⁶ pcDNA3f-CCL21 and pcDNA3f-CCL21-Fc were provided by Dr. H.J. Qin (Chinese Academy of Medical Sciences, Beijing, People’s Republic of China), which were constructed by inserting the sequence of human CCL21 or CCL21-Fc into pcDNA3f, respectively.

The fragments of hTERT were synthesized by successive PCR with the following primers.

- primer S1-GAATTCGTTCCCTGCTTCGGAGCCACTACCGCGAGGTGCTC
- primer S2-CACTACCGCGAGGTGCTCCCGCTGGCCACGTTTCGTGCGGCGCCTGGGTCTCAAGGCTG
- primer S3-GCCTGGGTCTCAAGGCTGGCGGCTGGTTCAGCGTGGCGATCCGCGCGCTTCCGT
- primer S4-CGATCCGGCGGCTTCCGTGCGCTGGTGGCCAGGAAGTCTCGGGTCTTTTC
- primer S5-GGAAGTCTCGGGTCTTTCTTTTATGTACAGGAGACCAGTTTCAAAGAACAGGCTC
- primer S6-GAATTCGCACAATGACCCGTTCCCTGCTCGGAGCCAC
- primer A1-GCTTTGCAGCTTGCTCCAGACACTCTTCCGTAGAAAAAGAGCCTGTTCTTTTGAAC
- primer A2-CCGCAGTTGCACCCTCTCAAGTGCTGTCTGATTCCAATGCTTTGCAGCTTGCTCCAG

primer A3-GGCTTCCCAGTGTGCTGCCTGACCTCTGCTTCGACAGTTCCCAGATTGCACCCTCTTC

primer A4-GATGAAGCGGAGTCTGGACGTACGAGGGCGGGCCTGGCTTCCCAGTGTGCTGCTG

primer A5-GATATCAATCGGCCGACCCGTCAGGCTTGGGGATGAAGCGGAGTCTGGAC

primer A6-GATATCTCAAATCGGCCGACCCGTC

Primers were assembled by successive PCR using 10 ng of inner primers (S2–S5, A1–A4) and 200 ng of external primers (S1 and A5), which contained suitable restriction cleavage sites for cloning. The condition of PCR for hTERT synthesis was described as the following: first 94°C 30 sec, 65°C 40 sec, 72°C 90 sec; 5 cycles and then 94°C 30 sec, 70°C 40 sec, 72°C 60 sec; 25 cycles. The product of the successive PCR was 378bp. A stop codon was added to 3-end of the 378bp hTERT fragment with the primers S1 and A6. The hTERT fragment with a stop codon (381bp) was digested with EcoRI and EcoRV restriction enzymes, and then cloned into the corresponding sites of pcDNA3f-sig (pC) and pcDNA3f-CCL21 (pCCL21) to generate pcDNA3f-sig-Te (psTe) and pcDNA3f-CCL21-Te (pCCL21-Te), respectively (Fig. 1). The hTERT fragment without a stop codon (378bp) was also digested with EcoRI and EcoRV and inserted into pcDNA3f-sig-Fc (pFc) and pcDNA3f-CCL21-Fc (pCCL21-Fc) to generate pcDNA3f-sig-Te-Fc (pTe-Fc) and pcDNA3f-CCL21-Te-Fc (pCCL21-Te-Fc), respectively (Fig. 1). An initiation codon was added to the 381 bp hTERT fragment with the primers S6 and A6. After digestion with EcoRI and EcoRV, the DNA product was cloned into the corresponding sites of pcDNA3f to generate pcDNA3f-Te (pTe) (Fig. 1). All recombinant constructs were confirmed on a DNA sequencer (ABI3730, PE Applied Bio Systems, Beijing, P.R. China) to ensure the integrity of the reading frame in these fusion constructs.

Cell transfection

Tumor cells were transfected with plasmid DNA by lipofection using Lipofectamine Plus reagent (Invitrogen Life Technologies) according to the manufacturer’s protocol and grown in the presence of selective antibiotics G418 (800µg/ml, Invitrogen Life Technologies). The positive clones were selected by limiting dilutions in 96-well plates. B16/CCL21, B16/Fc, B16/sTe, B16/CCL21-Te, B16/CCL21-Fc, B16/Te-Fc and B16/CCL21-Te-Fc which could express secreted fusion proteins were obtained by stably transfecting B16 tumor cells with pCCL21, pFc, psTe, pCCL21-Te, pCCL21-Fc, pTe-Fc and pCCL21-Te-Fc, respectively. B16 and U2OS were transfected with pTe, respectively to get B16/Te and U2OS/Te. As a control, B16 was transfected with empty vector (pC) to create B16/C. Reverse transcription PCR

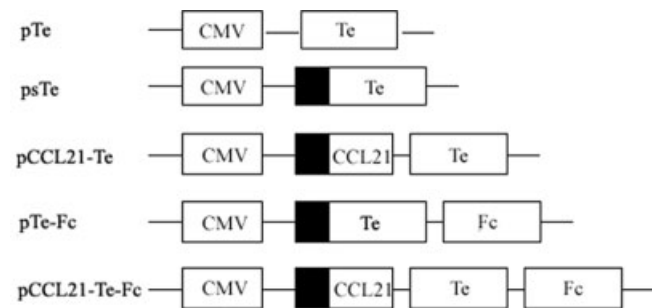

FIGURE 1 – Construction of the recombinant vectors. The hTERT fragment with a stop codon was digested with EcoRI and EcoRV restriction enzymes, and then cloned into the corresponding sites of pcDNA3f-sig and pcDNA3f-CCL21 to generated psTe and pCCL21-Te, respectively. The hTERT fragment without a stop codon was digested by EcoRI and EcoRV and inserted into pcDNA3f-sig-Fc and pcDNA3f-CCL21-Fc to generate pTe-Fc and pCCL21-Te-Fc, respectively. The hTERT fragment with the initiation codon and stop codon was inserted into pcDNA3f to generate pTe. CMV, the promoter of pcDNA3f. ■, the signal sequence of human CCL21.

and western blots were used to confirm the expression of the transgenes in these positive clones.

Chemotaxis assays

Human PBMCs were isolated from heparinized blood of HLA-A*0201⁺ healthy donor by Ficoll-Hypaque density gradient centrifugation. The chemotactic responses of CCL21 to human PBMCs and mouse splenocytes were examined by using a chemotaxis microchamber technique (48-well Boyden microchamber; Neuro Probe, Beijing, P.R. China). The transfected tumor cells were cultured in RPMI 1640 with 10% FCS for 48 hr, and then the culture supernatants were harvested and added to the lower wells of the microchemotaxis chamber. Human PBMCs or mouse splenocytes were applied to the upper wells of the chamber at 10⁶ cells/well in 50 μ l RPMI 1640 containing 10% FCS, with a standard 5- μ m pore polyvinylpyrrolidone-free polycarbonate filter separating it from the lower wells. After incubation for 4 hr at 37°C, nonmigrated cells were removed from the upper well and the upper membrane was wiped, then the membrane was fixed in 70% methanol and stained with Giemsa. The number of cells that had migrated was counted in 10 random high-power fields (200 \times magnification). The results were expressed as the fold increases in cells migrating in response to chemoattractant *versus* the negative control (chemotaxis index). All samples were pretreated in triplicate and the experiments were repeated a minimum of 3 times.

Therapeutic study with DNA vaccination or gene-modified tumor cells vaccination

Female C57BL/6 mice, 6–8 weeks of age were purchased from the Experimental Animal Institute of Peking Union Medical College. All animal procedures were done according to the approved protocols and in accordance with recommendations for the proper use and care of laboratory animals. To establish local tumor, 5 \times 10⁴ B16/Te cells expressing hTERT in 100 μ l PBS were s.c. inoculated at the right flank back of recipient mice on day 0. The DNA vaccination or gene-modified tumor cells vaccination were done on days 5, 10 and 15. Tumor growth was monitored every 2–3 days by palpation, and tumor size was measured in 2 perpendicular tumor diameters as described previously.¹⁶ For DNA vaccination, the Helios gene gun system (Bio-Rad, Hercules, CA) was used for intradermal gene delivery. Bullets containing 1.25 μ g of DNA/shot were generated according to the manufacturer's protocols. For genetically modified tumor cells vaccination, the modified tumor cells (10⁶ cells/ml) were pretreated with mitomycin-C (80 μ g/ml) for 45 min and then washed with PBS for 3 times. The mice were s.c. vaccinated at the left flank back with 1.5 to 2 \times 10⁶ the pretreated tumor cells.

To study the therapeutic effects of the combination treatment, mice were s.c. inoculated with 5 \times 10⁴ B16/Te tumor cells at the right flank on day 0, then immunized s.c. with 1.5 to 2.0 \times 10⁶ the modified tumor cells pretreated with mitomycin-C on days 7 and 11. On days 8, 11 and 14, 100 μ g of anti-4-1BB (clone 2A, kindly provided by Dr. L.P. Chen) or control rat Ig was given intraperitoneally (i.p.) in 500 μ l of PBS. In the pulmonary metastasis model, mice were infused 1 \times 10⁵ B16/Te cells in 100 μ l of PBS *via* tail vein on day 0, and then treated as mentioned earlier. On day 23, all mice were sacrificed and tumor nodules more than 0.5 mm in diameter were counted on the lung surface.

In vitro cytotoxicity assay

Female C57BL/6 mice were s.c. challenged with 5 \times 10⁴ B16/Te cells in the right flank back on day 0, then s.c. immunized with the gene-modified tumor cells pretreated with mitomycin-C. Ten days after the last booster, splenocytes from the immunized mice were prepared as effector cells. Cytotoxicity assays were performed using a CytoTox 96[®] NonRadioactive Cytotoxicity Assay kit (Promega, Madison, WI) according to the manufacturer's instructions. The ratio of effector cells to target cells were 10:1, 20:1 and 40:1 (tested in triplicate).

In vivo depletion of lymphocytes by MAbs

CD4⁺ T cells and CD8⁺ T cells depletion *in vivo* were performed by administering anti-CD4 (GK1.5) and anti-CD8 (2.43) ascites fluids, which were generated by injection of hybridoma cells into pristane-primed nude mice i.p. The ascites fluids (100 μ l) were administered i.p. every other day for 3 times prior to the first vaccination, then the administration continued twice per week until sacrifice. For depletion of NK cells, polyclonal rabbit antiasialo GM1 antibody (200 μ g/mouse) (Wako, Tokyo, Japan) was i.p. injected into the mice every day for 5 consecutive days before the first vaccination, then the administration continued in 3-day intervals until sacrifice. Control Ig was used in the same way. Antibody treatment resulted in >97% depletion of specific lymphocytes subsets of representative animals by flow cytometry (Becton Dickinson, Mountain View, CA).

Generation of HLA-A*0201-restricted and hTERT-specific CTL from human PBMCs

Human PBMCs, isolated from heparinized blood of HLA-A*0201⁺ healthy donor by Ficoll-Hypaque density gradient centrifugation, were stimulated at 1 \times 10⁶ cells/ml with 10 μ g/ml LPS for 24 hr. The activated PBMCs were washed twice with serum-free RPMI 1640 and transfected with pCCL21-Te-Fc and pC, respectively. Nontansfected PBMCs were cocultured with transfected PBMCs in the presence of human recombinant IL-2 (hrIL-2) (25 U/ml). Cultures and cytokines were refreshed on days 3 and 6. On day 7, PBMCs were restimulated under the same conditions as the initial stimulation. The stimulated HLA-A*0201⁺ PBMCs were harvested on day 14 and used as effector cells in cytotoxicity assay. Cytotoxicity assays were performed using a CytoTox 96[®] NonRadioactive Cytotoxicity Assay kit (Promega, Madison, WI) according to the manufacturer's instructions. T2, MCF-7, SK-OV-

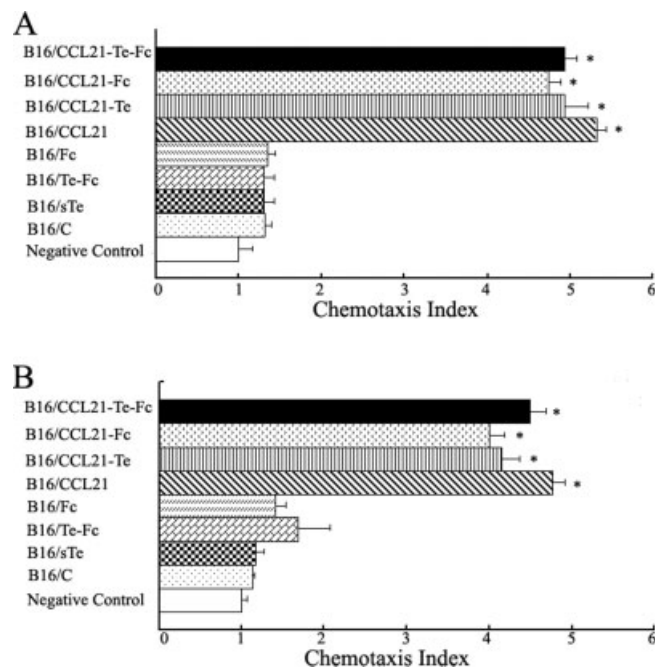

FIGURE 2 – Chemotactic attraction of lymphocytes from (a) human PBMCs and (b) mouse spleen by culture supernatants of the genetically modified tumor cell. Chemotactic activity of the culture supernatants from B16 cells transfected with pCCL21-Te-Fc, pCCL21-Te, pCCL21-Fc, pCCL21, psTe, pTe-Fc, pFc and pC, respectively were measured as the fold increases in lymphocytes migrating in response to chemoattractant *versus* negative control (chemotaxis index). **p* < 0.05 relative to B16/C by Student's paired *t*-test.

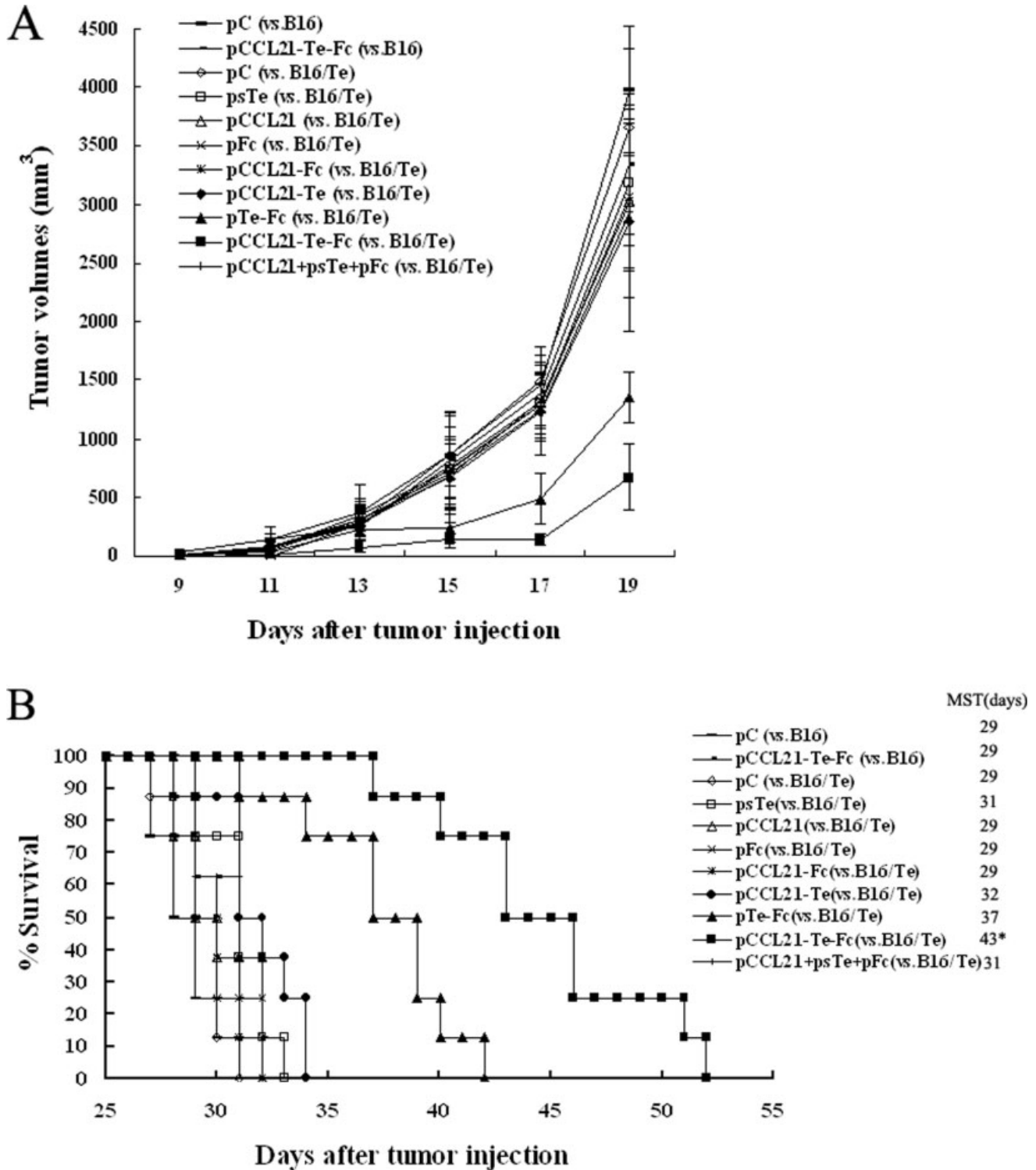

FIGURE 3 – Induction of the therapeutic anti-tumor immunity by DNA vaccination. C57BL/6 mice were s.c. challenged with 5×10^4 B16/Te or B16 on day 0 ($n = 8$). Then the mice were s.c. vaccinated with DNA vaccine by gene gun inoculation on days 5, 10 and 15. The vaccination of pCCL21 + psTe + pFc was pCCL21, psTe and pFc simultaneously injected by gene gun at the same site. (a) Tumorigenic growth was monitored every 2 days by palpation, and the size of tumor was measured with calipers. The values represent mean \pm SE of tumor volume (mm³) of 8 mice. (b) Survival was monitored over time after tumor inoculation, and the median survival time (MST; in days) was determined. * $p < 0.05$ for pCCL21-Te-Fc(vs. B16/Te)vaccination versus all other groups by log-rank test.

3, SK-BR3, PC-3M, LNCap, U2OS/Te and U2OS cells were used as target cells and cocultured with effector cells at a ratio of 1:15, 1:30 and 1:60 (tested in triplicate).

Statistical analysis

Statistical significance of difference between the 2 groups was determined by applying Student's paired *t*-test. The Kaplan-Meier

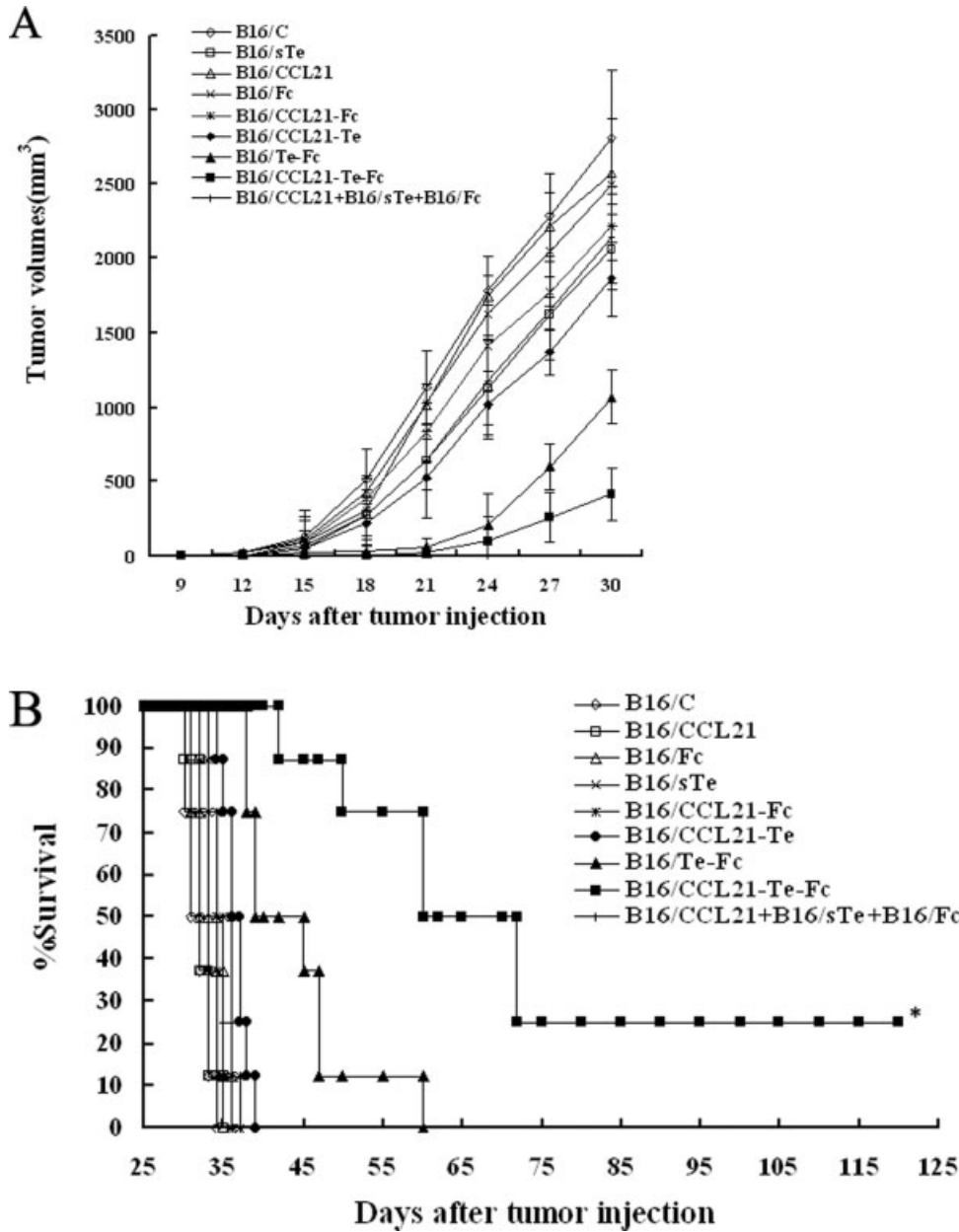

FIGURE 4 – Induction of the therapeutic antitumor immunity by vaccination with modified tumor cells. C57BL/6 mice were s.c. challenged with 5×10^4 B16/Te on the right flank back on day 0, then the mice were s.c. vaccinated with modified tumor cells pre-treated by mitomycin-C on the left flank back on days 5, 10 and 15 ($n = 8$). (a) Tumorigenic growth was monitored twice per week by palpation, and the size of tumor was measured with calipers. The values represent mean \pm SE of tumor volume (mm^3) of 8 mice. (b) Survival of mice per treatment group. * $p < 0.001$ relative to a group vaccinated with B16/C by log-rank test.

plot for survivals was assessed for significance using the log-rank test (SPSS 12.0). A value of $p < 0.05$ was considered significant.

Results

Construction of DNA plasmids and characterization of the genetically modified tumor cells

The cDNA of hTERT (GenBank accession no. AB085628) was analyzed by peptide-motif scoring system (http://bimas.dcrf.nih.gov/molbio/hla_bind/ or <http://www.syfpeithi.de/>) to select epitopes that could potentially bind to HLA class I or class II molecules. Two fragments encoding multiple CTL and Th epitopes were selected. One locates from 31bp to 159bp and the other is from 1663bp to 1899bp. The 2 fragments were synthesized into 1 by successive PCR. To avoid generating new epitope when the 2 fragments fused, the fourth amino acid (R) in the second fragment was mutated to G according to the peptide-motif scoring system mentioned above. The PCR product with a stop codon (381bp) was inserted into pcDNA3f-sig (pC) and pcDNA3f-CCL21 (pCCL21) to generate pcDNA-sig-Te (psTe) and pcDNA3f-CCL21-Te (pCCL21-

Te), respectively (Fig. 1). The recombinant plasmids pcDNA3f-sig-Te-Fc (pTe-Fc) and pcDNA3f-CCL21-Te-Fc (pCCL21-Te-Fc) were constructed by inserting the hTERT fragment without a stop codon (378bp) into pcDNA3f-sig-Fc (pFc) and pcDNA3f-CCL21-Fc (pCCL21-Fc), respectively (Fig. 1). The plasmid pcDNA3f-Te (pTe) was constructed by inserting the hTERT fragment with the initiation codon and stop codon into pcDNA3f (Fig. 1). B16 tumor cells were transfected with plasmids of pC, psTe, pCCL21, pFc, pCCL21-Te, pCCL21-Fc, pTe-Fc and pCCL21-Te-Fc to create the following stable cell lines of B16/C, B16/sTe, B16/CCL21, B16/Fc, B16/CCL21-Te, B16/CCL21-Fc, B16/Te-Fc and B16/CCL21-Te-Fc, respectively. U2OS/Te and B16/Te were created by stably transfecting pTe into U2OS and B16, respectively, which expressed the nonsecreted hTERT. The gene-modified tumor cells and their parental cells had similar cell proliferation *in vitro* and the tumorigenicity of B16/Te was identical with that of B16 (data not shown).

The expression of recombinant fusion proteins in the transfected cells was confirmed by RT-PCR and western blots analysis (data

not shown). To test whether the expressed human CCL21 were functional for human and mouse lymphocytes, the culture supernatants of the modified tumor cells were harvested 48 hr later and assessed for their ability to induce lymphocytes migration *in vitro*. As shown in Figure 2, supernatants from B16/CCL21, B16/CCL21-Te, B16/CCL21-Fc and B16/CCL21-Te-Fc attracted both mouse lymphocytes and human PBMCs at a similar level. However, the supernatants from B16/sTe, B16/Te-Fc, B16/Fc and B16/C had no significant chemotactic response either to human PBMCs (Fig. 2a) or to mouse lymphocytes (Fig. 2b). These results demonstrated that the human CCL21 in all of our constructs was functional and had the similar ability to attract human and mouse lymphocytes. Moreover, the chemotactic activity of the secreted protein CCL21-Te-Fc was same to that of CCL21 in the animal model (data not shown).

Antitumor activity induced by DNA vaccination

To assess whether CCL21 and Fc could cooperatively enhance the therapeutic effect of the hTERT-based vaccine, C57BL/6 mice were vaccinated with pC, psTe, pCCL21, pFc, pCCL21-Te, pCCL21-Fc, pTe-Fc, pCCL21-Te-Fc and pCCL21 + psTe + pFc, respectively by gene gun inoculation on days 5, 10 and 15 after tumor challenge. Measurements of tumor growth indicated that the antitumor effects induced by DNA vaccination with pCCL21, psTe, pFc, pCCL21-Fc and pCCL21-Te, respectively were limited and all of the mice were dead within 34 days (Fig. 3). The mice vaccinated with pTe-Fc had partially reduced tumor growth (Fig. 3a) and survived until day 42, the median survival time (MST) was 37 days (Fig. 3b). This result was in agreement with our previous study that vaccination with antigen conjugated to the Fc increased the antitumor effect.¹⁶ The mice vaccinated with pCCL21-Te-Fc had the lowest average tumor volumes compared with those treated with the other DNA vaccines. The mice survived 52 days and the MST was 43 days (Fig. 3b). These results indicated that vaccination with pCCL21-Te-Fc could induce the strongest antitumor effect. Additionally, the antitumor effect induced by pCCL21 + psTe + pFc was similar to that induced by psTe ($p = 0.7344$, by log rank test; Fig. 3b), implying that the expression of CCL21 and Fc with Te as a fusion protein is necessary to generate optimal immunity. To test whether hTERT was the main contributor to the antitumor response, we treated mice with B16 tumor cells. As shown in Figure 3, pCCL21-Te-Fc vaccination had no effect on the tumor growth and the mice survival in B16 tumor mode, suggesting that the antitumor immune response induced by pCCL21-Te-Fc vaccination might be specifically against hTERT.

Antitumor activity induced by genetically modified tumor cells

Although CCL21 and Fc synergistically enhanced the immunogenicity of hTERT-based DNA vaccine, no mice had a complete tumor regression. To achieve more effective antitumor response, the tumor-bearing mice were s.c. vaccinated with gene-modified tumor cells pretreated with mitomycin C on days 5, 10 and 15. As shown in Figure 4a, tumor growth was significantly inhibited in mice vaccinated with B16/CCL21-Te-Fc, whereas tumors grew progressively in other groups. On day 60, 50% of mice in the B16/CCL21-Te-Fc-treated group survived, while mice in the other groups were dead. On day 120, there were 25% of mice in this group (2/8 animals) achieved long-term survival with complete tumor regression (Fig. 4b). As shown in Figure 5, the CTL activity induced by B16/CCL21-Te-Fc was higher than others, which was consistent with the antitumor activity shown in B16/Te bearing mice (Fig. 4). Collectively, the chemotactic-hTERT modified tumor cell vaccine (B16/CCL21-Te-Fc) induced a stronger antitumor response than other vaccines.

Antitumor activity induced by the combined action of chemotactic-hTERT modified tumor cell vaccine with anti-4-1BB costimulation

The earlier studies stated that the administration of anti-4-1BB MAbs could promote the effective immune responses by priming

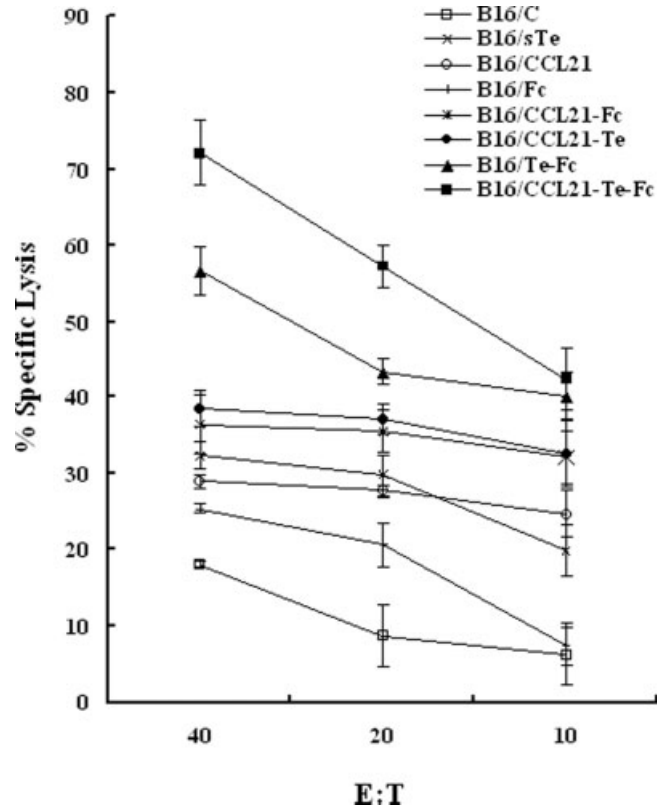

FIGURE 5 – The CTL activities induced by modified tumor cells vaccination in the therapeutic study against B16/Te targets. C57BL/6 mice were treated as Figure 4 described ($n = 3$). Ten days after the last immunization, splenocytes were prepared as effector cells.

and expanding CD8⁺ T cell repertoire.^{17,21} Our preliminary study confirmed the synergism between anti-4-1BB and DNA vaccines in generating antitumor effects. Although pCCL21-Te-Fc plus anti-4-1BB induced the stronger immune response than other controls, the response was not sufficient to retard tumor growth and no mice achieved long-term survival with completed tumor regression (data not shown). So we decided to evaluate whether the modified tumor cell vaccine plus anti-4-1BB MAbs would result in a more effective antitumor response. Mice were s.c. inoculated with tumor cells on day 0, then vaccinated s.c. with modified tumor cells pretreated with mitomycin-C on days 7 and 11, and anti-4-1BB MAbs or control rat Ig was administrated i.p. on days 8, 11 and 14. As illustrated in Figure 6a, the combination of B16/CCL21-Te-Fc and anti-4-1BB MAbs resulted in the greatest reduction of tumor growth and significant improvement of the mice survival as shown in Figure 6b. On day 120, 75% of mice in this group (6/8 animals) achieved long-term survival with complete tumor regression. In addition, we also compared the immune responses induced by B16/CCL21-Te-Fc plus anti-4-1BB with that induced by B16/Te-Fc plus anti-4-1BB to further make sure the potency of CCL21 in the antitumor immune response. Data in Figure 6c showed that the treatment with B16/Te-Fc plus anti-4-1BB delayed tumor growth less effectively compared with B16/CCL21-Te-Fc alone or B16/CCL21-Te-Fc plus anti-4-1BB, and all mice dead within 64 days (Fig. 6d). This result suggested that CCL21 was necessary to be included into the modified tumor vaccine to induce a long-term antitumor response.

We further evaluated the antitumor effect of B16/CCL21-Te-Fc plus anti-4-1BB in cytotoxicity assay and pulmonary metastasis model, respectively. Tumor-bearing mice were treated as mentioned in Figure 6a, and 10 days after the last booster, splenocytes from the immunized mice were prepared as effector cells. As

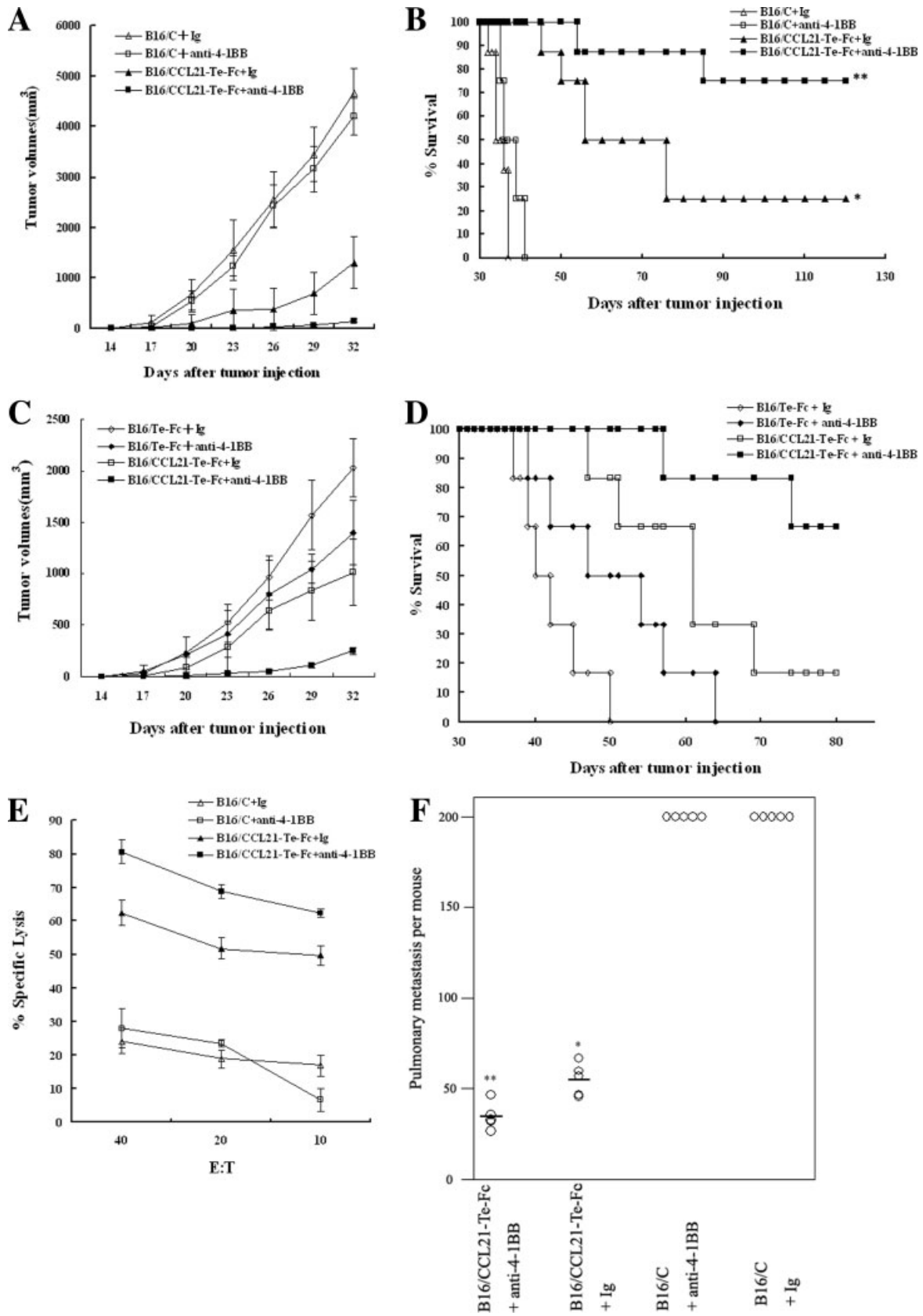

FIGURE 6.

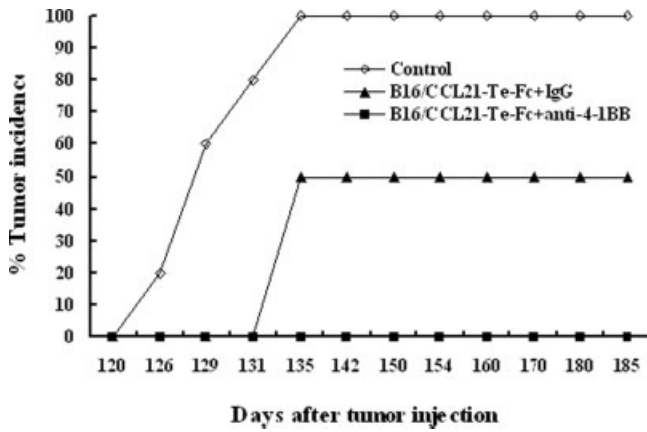

FIGURE 7 – Evaluation of persistent antitumor response. The tumor-free mice from B16/CCL21-Te-Fc + Ig-treated group ($n = 2$) or B16/CCL21-Te-Fc + anti-4-1BB-treated group ($n = 5$) were s.c. rechallenged with 10^5 B16/Te cells on day 120 after the initial tumor inoculation. As a control, naïve mice were treated in the same way ($n = 5$). Tumor incidence was monitored over time after tumor inoculation.

shown in Figure 6e, significantly higher CTL activity was observed in mice treated with B16/CCL21-Te-Fc plus anti-4-1BB MAbs compared with the use of either reagent alone. In pulmonary metastasis model, mice were inoculated with 1×10^5 B16/Te cells *via* tail vein on day 0 and then treated as described in Figure 6a. All mice were sacrificed to enumerate the number of lung tumor nodules on day 23. As is evident in Figure 6f, the B16/CCL21-Te-Fc vaccination dramatically reduced the tumor nodules in the lung, and the combination with anti-4-1BB treatment further reduced lung metastasis. All of these results suggested that there was an additive effect from combining B16/CCL21-Te-Fc vaccination and anti-4-1BB, resulting in significant antitumor response.

To evaluate the persistent protective effect of the combined therapy, the survivors with complete tumor regression in Figure 6a and the naïve control mice were s.c. rechallenged with 10^5 B16/Te tumor cells on day 120 after the initial tumor inoculation. No mice from the group treated with B16/CCL21-Te-Fc and anti-4-1BB developed tumors after an additional 60 days. In contrast, 50% of the mice from the group treated with B16/CCL21-Te-Fc plus control Ig developed tumor (Fig. 7). The observation of long-term immunity implies that B16/CCL21-Te-Fc plus anti-4-1BB may successfully mediate the development of persistent memory immune response.

Involvement of CD8⁺, CD4⁺ T cells and NK cells in tumor regression in vivo

We next sought to identify the effector cells involved in the tumor rejection response associated with the combination therapy by depleting NK cells, CD4⁺ T cells and CD8⁺ T cells, respectively. We carried out *in vivo* depletion of leukocyte subsets on day 2 after tumor challenge in subcutaneous tumor model. As shown in Figure 8a, the CTL activity induced by the treatment of B16/CCL21-Te-Fc plus anti-4-1BB was completely abrogated by

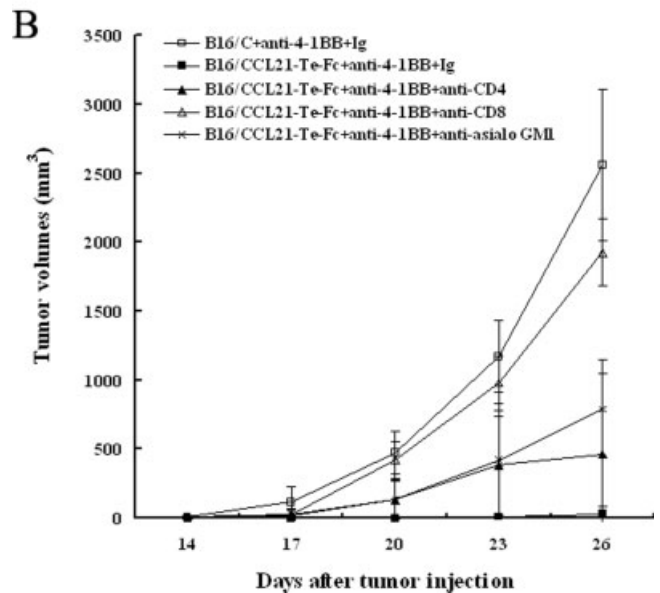
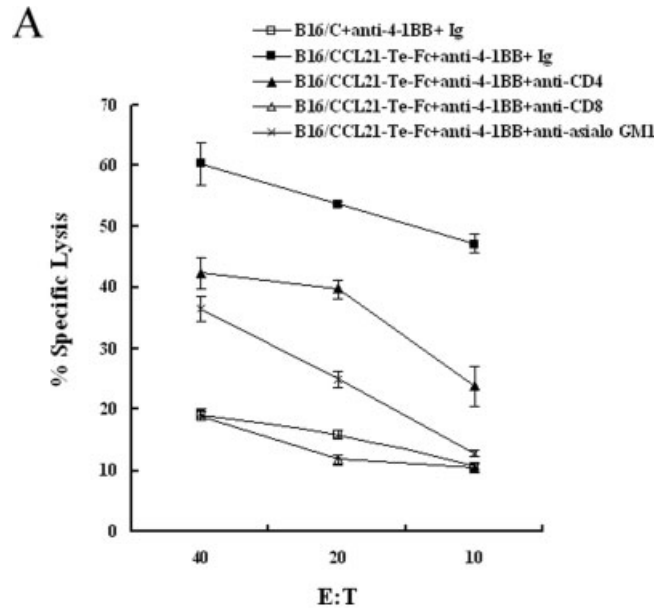

FIGURE 8 – Assessment of involvement of NK cells, CD4⁺ and CD8⁺ T cells in antitumor effect. Animals were s.c. challenged with 5×10^4 B16/Te cells on day 0, then treated with B16/CCL21-Te-Fc or B16/C plus anti-4-1BB ($n = 4$) as Figure 6a described. Cell subsets were depleted by the injection of GK1.5 (for CD4⁺ T cells), 2.43 (for CD8⁺ T cells) ascites fluids (100 μ l/mouse) on days 2, 4 and 6, then twice a week before killing. For NK cells depletion, asialo-GM1 antibodies (200 μ g/mouse) were injected for 5 consecutive days beginning on day 2, then twice a week before killing. The control Ig was injected in the same way. (a) Abrogation of CTL-mediated cytotoxicity. (b) The s.c. tumor size was measured twice per week.

FIGURE 6 – Evaluation of the combination therapeutic effect on established tumor. C57BL/6 mice were inoculated s.c. with 5×10^4 B16/Te tumor cells on day 0 and were treated with modified tumor cells immunization on days 7 and 11 followed by either rat Ig or anti-4-1BB MAbs administration (*i.p.*) on days 8, 11 and 14. (a) Data were reported as the average tumor volumes \pm SE of 8 mice per group that vaccinated with B16/CCL21-Te-Fc or B16/C followed by either Ig or anti-4-1BB treatment. (b) Survival of mice per group treated as Figure 6a. * $p < 0.001$ versus B16/C + Ig and B16/C + anti-4-1BB; ** $p < 0.05$ versus B16/CCL21-Te-Fc + Ig by log-rank test. (c) The average tumor volumes \pm SE of 6 mice per group that vaccinated with B16/CCL21-Te-Fc or B16/Te-Fc followed by either Ig or anti-4-1BB treatment. (d) Survival of mouse per group treated as Figure 6c. (e) CTL induced by the combination therapy stated as Figure 6a in the s.c. implanted tumor model. (f) Evaluation of therapeutic effect on established pulmonary metastases. C57BL/6 mice were challenged *via* tail vein with 1×10^5 B16/Te tumor cells on day 0 ($n = 5$), and vaccinated as Figure 6a described. The lung metastatic nodules were counted on day 23. * $p < 0.001$ versus B16/C + Ig and B16/C + anti-4-1BB by Student paired *t*-test; ** $p < 0.05$ versus B16/CCL21-Te-Fc + Ig by Student paired *t*-test.

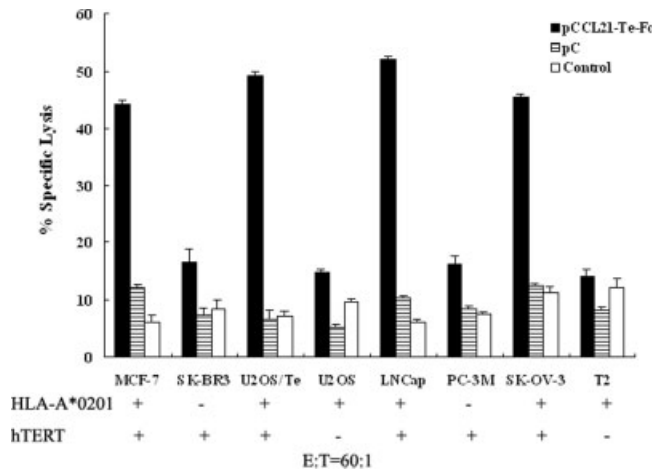

FIGURE 9 – HLA-A*0201-restricted and hTERT-specific CTLs lysed human cancer cells. Human PBMCs were stimulated with LPS (10 μ g/ml) for 24 hr in complete medium, and then transfected with pCCL21-Te-Fc and pC, respectively. Nontransfected PBMCs were cocultured with the transfected PBMCs in the presence of human recombinant IL-2 (hrIL-2) (25U/ml). Cultures and cytokines were refreshed on days 3 and 6. On day 7, PBMCs were restimulated under the same conditions as the initial stimulation. The stimulated HLA-A*0201⁺ PBMCs were harvested on day 14 and tested for cytolytic activity against human cancer cells MCF-7, SK-BR3, U2OS/Te, U2OS, LNCap, PC-3M, SK-OV-3 and T2.

the depletion of CD8⁺ T cells ($p < 0.0001$, by Student paired t -test). Partial abrogation was observed by the depletion of CD4⁺ T cells ($p = 0.0065$, by Student paired t -test) or NK cells ($p = 0.0027$, by Student paired t -test). Similar results were obtained in the analysis of local tumor size development (Fig. 8b). These results indicated that CD8⁺ T cells were essential in the antitumor activity induced by B16/CCL21-Te-Fc plus anti-4-1BB MAbs, whereas NK cells and CD4⁺ T cells played substantial roles.

HLA-A*0201-restricted and hTERT-specific CTLs lysed human cancer cells

The preceding results provided strong information that the hTERT fragment could be efficiently presented in animal model. Next, we tested whether the epitopes of hTERT could be efficiently presented by human antigen-presenting cells and induced hTERT-specific CTL. HLA-A*0201⁺ PBMCs transfected with pCCL21-Te-Fc were used to stimulate autologous lymphocytes *in vitro*, and the cytotoxicity of the induced CTL was evaluated against a panel of tumor cells with diverse histological origins. Data in Figure 9 showed that the cytotoxicity was dependent on the expression of HLA-A*0201 molecule because tumor-matched cell lines with different HLA type were not lysed (cell lines SK-BR3 and PC-3M). At the same time the CTL only lysed the hTERT-positive cell line but not the hTERT-negative cell line (U2OS cell line), further demonstrating antigen specificity of the cytotoxic response. Taken together, these data indicated that the selected hTERT might be naturally processed by human antigen-presenting cells and induced hTERT-specific CTL against hTERT-positive human tumor cells.

Discussion

As a potential molecular therapeutic target for cancer, hTERT has been intensively scrutinized due to its universal expression in human cancers and its critical functional role in tumor growth and development. At the present time, tumor vaccination targeting hTERT has been mainly directed to pulse DCs with single peptide or transfect DCs with hTERT mRNA.^{3,6} In this study, we demon-

strated the feasibility of constructing chemotactic-hTERT vaccine by sandwiching hTERT polypeptides between CCL21 and IgG Fc fragment. Our data indicated that the chemotactic-hTERT vaccination could induce a remarkable antitumor effect against hTERT-expressing tumor.

The stringent procedures to facilitate the preferential generation of higher antitumor efficacy were made. One of the strategies was to modify tumor cells with chemotactic-hTERT. Analysis of the antitumor response confirmed our hypothesis that higher effect was induced by the modified tumor cells vaccination (Fig. 4). The difference between the responses induced by DNA vaccination and the modified tumor cells vaccination might be attributed to several reasons. First, the antitumor response elicited by the modified tumor cells was directed against a mixture of tumor antigens encoded by the tumor cells and the corresponding oligo- or polyclonal responses could be more potent than a monoclonal response. Second, chemotactic-hTERT gene modification increased the immunogenicity of the tumor cells (data not shown). This modification might offer the possibility to trigger the recruitment of initiators or effectors of the immune response within the tumor, providing a microenvironment that favors innate and/or acquired immune mechanisms to prevent or reverse tumor development. Based on these results, future development of this approach may lead to practical use in treating tumors. For example, tumor removed from patients by surgery could be gene-modified with the chemotactic-hTERT *in vitro*, then used as autologous cellular vaccine.

Another strategy to improve the immunotherapeutic efficacy of chemotactic-hTERT vaccine was focused on the combination with anti-4-1BB MAbs. The anti-tumor effect induced by DNA vaccine or modified tumor cells vaccine plus anti-4-1BB was evaluated, respectively. Both the combined therapies prolonged the survival of tumor-bearing mice. The treatment of B16/C plus anti-4-1BB had no significant effect against B16/Te tumor (Figs. 6a, 6b and 6f), suggesting the immunological ignorance of specific CTLs prevented costimulation of anti-4-1BB MAbs. Breaking CTL ignorance by immunization with a specific tumor antigen was necessary for anti-4-1BB MAbs to induce a specific CTL response against poorly immunogenic tumors. Similar results were also observed in other poorly immunogenic tumors, such as B16/D5, C3 and TC-1.^{22,23}

It was reported that murine CCL21 alone delivered *in vivo* either by chemokine-transfected tumors or by naked plasmid could enhance the antitumor immunity in established tumor models.^{10,12,24} Unfortunately, the data presented here showed that the human CCL21 alone failed to induce the immune responses against tumors in the mouse model either by pCCL21 or by pCCL21-transfected tumor cells (B16/CCL21) ($p = 0.0947$ and $p = 0.4213$ by log rank test in Figs. 3b and 4b, respectively). A possible explanation for this discrepancy might be (1) human CCL21, unlike murine CCL21, does not bind CXC chemokine receptor 3 (CXCR3) to block angiogenesis *in vivo*, even though it has similar chemotactic activity for human and mouse lymphocytes.^{12,24,25} (2) no hTERT-specific CTL was induced by vaccination with CCL21 alone. When vaccinated with B16/CCL21, there were no significant tumor-specific CTLs against B16/Te or the regression of established B16/Te tumors (Figs. 4 and 5). In contrast, it was significantly different when vaccinated with B16/CCL21-Te ($p = 0.0021$, by log rank test; Fig. 4b). Similar result was also observed when vaccinated with pCCL21-Te ($p = 0.0162$, by log rank test; Fig. 3b). It suggests that CCL21 work synergistically with specific tumor antigen, which may activate specific CTLs. However, the antitumor effect induced by pCCL21 + psTe + pFc or B16/CCL21 + B16/sTe + B16/Fc was similar to that induced by psTe or B16/sTe, respectively. This suggested the expression of CCL21 and Fc with specific antigen as a fusion protein might exert a more improved adjuvant activity than coadministration. The fusion expression of chemokine gene with an antigen in a plasmid might increase the concentration of the chemokine and recruit a large number of DCs and T cells in the vicin-

ity of cells that express the antigen, promoting the cell-mediated immune response against tumor. The fusion expression of IgG Fc fragment with antigen could mediate internalization of antigen-IgG complex and allow DCs to present antigen *via* MHC class II and MHC class I pathways in a cognate manner, which could further augment antigen-specific immunity.¹³⁻¹⁵ Therefore, another implication of our study is the expression of chemokine and IgG Fc fragment with specific antigen as a fusion protein would facilitate the generation of optimal immunity.

We studied the involvement of CD8⁺, CD4⁺ T cells and NK cells in the antitumor reactivity of the combined therapy with B16/CCL21-Te-Fc plus anti-4-1BB. Among these cells, CD8⁺ T cells were more crucial for the tumor eradication compared with CD4⁺ T cells and NK cells (Fig. 8). The major role of CD8⁺ cells as effectors might be related to the relatively higher expression of 4-1BB on CD8⁺ cells compared with CD4⁺ cells after T-cell receptor engagement.^{26,27} The depletion of NK cells partially abrogated the antitumor response of therapy, which was consistent with the recent reports that anti-4-1BB could stimulate NK cells to promote the expansion of CD8⁺ T cells thus providing another form of help to CTL.^{28,29} This dependency on the participation of NK cells for the development of tumor specific T cells illuminates a link between innate and acquired immune responses in our combination therapy. Whether CD4⁺ T cells play a beneficial role in antitumor immunity remains controversial. Different tumor models and different treatment modalities have yielded different results.²⁹⁻³³ Data herein was in sharp contrast to some investigators who claimed that 4-1BB signaling enable CTL priming in the absence of CD4⁺ T cells,²⁹⁻³¹ but consistent with others who suggested that CD4⁺ T cells were required to provide a help to CD8⁺ response.^{32,33}

With clinical applications in mind, we further analyzed whether pCCL21-Te-Fc could stimulate CTL that specifically recognized and lysed hTERT-expressing human tumor cells *in vitro*. We focused on HLA-A*0201⁺ individuals because the population frequency of HLA-A*0201 is nearly 50% in several different ethnic groups allowing for the future treatment of a significant proportion of the patient population.³⁴ The CTL induced by pCCL21-Te-Fc-transfected HLA-A*0201⁺ PBMCs mediated efficient lysis of a variety of HLA-A*0201⁺ and hTERT⁺ human cancer cells such as prostate, breast and ovarian cancers (Fig. 9), underscoring the potential advantage of hTERT immunization in a large variety of human cancers. In view of the fact that hTERT is reactivated in proliferating tissues such as activated T and B cells, hematopoietic progenitors, germ cells and cells within intestinal and liver tissue, it is essential to determine whether immunization against hTERT could result in autoimmune damage of normal cells. Presently, we do not have evidence of autoimmunity in mice vaccinated with the chemotactic-hTERT vaccine. Additional studies on the safety of our regime also remain to be addressed.

Taken together, several features of our experimental system described here have important implications for the future study: (1) The chimeric construct of CCL21 and IgG Fc fragment with specific antigen dramatically improved the antitumor effect, providing a novel approach to design tumor vaccine. (2) The CTL induced by pCCL21-Te-Fc-transfected PBMCs specifically lysed a variety of HLA-matched and hTERT-positive cancer cells, suggesting the possibility for the future clinical trial against most human cancers. (3) The combined therapy of hTERT-based vaccines with anti-4-1BB significantly improved the antitumor effect; such findings are very encouraging for subsequent clinical development.

References

- Lewis JD, Reilly BD, Bright RK. Tumor-associated antigens: from discovery to immunity. *Int Rev Immunol* 2003;22:81-112.
- Kim NW, Piatyszek MA, Prowse KR, Harley CB, West MD, Ho PL, Coviello GM, Wright WE, Weinrich SL, Shay JW. Specific association of human telomerase activity with immortal cells and cancer. *Science* 1994;266:2011-15.
- Su Z, Dannull J, Yang BK, Dahm P, Coleman D, Yancey D, Sichi S, Niedzwiecki D, Boczkowski D, Gilboa E, Vieweg J. Telomerase mRNA-transfected dendritic cells stimulate antigen-specific CD8⁺ and CD4⁺ T cell responses in patients with metastatic prostate cancer. *J Immunol* 2005;174:3798-807.
- Rosenberg SA. A new era for cancer immunotherapy based on the genes that encode cancer antigens. *Immunity* 1999;10:281-7.
- Vonderheide RH. Telomerase as a universal tumor-associated antigen for cancer immunotherapy. *Oncogene* 2002;21:674-9.
- Vonderheide RH, Domchek SM, Schultze JL, George DJ, Hoar KM, Chen DY, Stephens KF, Masutomi K, Loda M, Xia Z, Anderson KS, Hahn WC et al. Vaccination of cancer patients against telomerase induces functional antitumor CD8⁺ T lymphocytes. *Clin Cancer Res* 2004;10:828-39.
- Schroers R, Huang XF, Hammer J, Zhang J, Chen SY. Identification of HLA-DR7-restricted epitopes from human telomerase reverse transcriptase recognized by CD4⁺ T-helper cells. *Cancer Res* 2002;62:2600-5.
- Campbell JJ, Bowman EP, Murphy K, Youngman KR, Siani MA, Thompson DA, Wu L, Zlotnik A, Butcher EC. 6-C-kine (SLC), a lymphocyte adhesion-triggering chemokine expressed by high endothelium, is an agonist for the MIP-3β receptor CCR7. *J Cell Biol* 1998;41:1053-9.
- Hedrick JA, Zlotnik A. Identification and characterization of a novel β chemokine containing six conserved cysteines. *J Immunol* 1997;159:1589-93.
- Gunn MD, Tangemann K, Tam C, Cyster JG, Rosen SD, Williams LT. A chemokine expressed in lymphoid high endothelial venules promotes the adhesion and chemotaxis of naive T lymphocytes. *Proc Natl Acad Sci USA* 1998;95:258-63.
- Jenh CH, Cox MA, Kaminski H, Zhang M, Byrnes H, Fine J, Lundell D, Chou CC, Narula SK, Zavadny PJ. Cutting edge: species specificity of the CC chemokine 6CKine signaling through the CXC chemokine receptor CXCR3: human 6CKine is not a ligand for the human or mouse CXCR3 receptors. *J Immunol* 1999;162:3765-9.
- Yang SC, Hillinger S, Riedl K, Zhang L, Zhu L, Huang M, Atianzar K, Kuo BY, Gardner B, Batra RK, Strieter RM, Dubinett SM et al. Intratumoral administration of dendritic cells overexpressing CCL21 generates systemic antitumor responses and confers tumor immunity. *Clin Cancer Res* 2004;10:2891-901.
- Ravetch JV. Fc receptors: rubor redux. *Cell* 1994;78:553-60.
- Regnault A, Lankar D, Lacabanne V, Rodriguez A, Thery C, Rescigno M, Saito T, Verbeek S, Bonnerot C, Ricciardi-Castagnoli P, Amigorena S. Fcγ receptor-mediated induction of dendritic cell maturation and major histocompatibility complex class I-restricted antigen presentation after immune complex internalization. *J Exp Med* 1999;189:371-80.
- Albert ML, Sauter B, Bhardwaj N. Dendritic cells acquire antigen from apoptotic cells and induce class I-restricted CTLs. *Nature* 1998;392:86-9.
- Qin H, Zhou C, Wang D, Ma W, Liang X, Lin C, Zhang Y, Zhang S. Specific antitumor immune response induced by a novel DNA vaccine composed of multiple CTL and T helper cell epitopes of prostate cancer associated antigens. *Immunol Lett* 2005;99:85-93.
- Shuford BW, Klussman K, Tritchler DD, Loo DT, Chalupny J, Sivadak AW, Brown TJ, Emswiler J, Raecho H, Larsen CP, Pearson TC, Ledbetter JA et al. 4-1BB costimulatory signals preferentially induce CD8⁺ T cell proliferation and lead to the amplification *in vivo* of cytotoxic T cell responses. *J Exp Med* 1997;186:47-55.
- Melero I, Johnston JV, Shufford WW, Mittler RS, Chen L. NK1.1 cells express 4-1BB (CDw137) costimulatory molecule and are required for tumor immunity elicited by anti-4-1BB monoclonal antibodies. *Cell Immunol* 1998;190:167-72.
- Langstein J, Schwarz H. Identification of CD137 as a potent monocyte survival factor. *J Leukoc Biol* 1999;65:829-33.
- Futagawa T, Akiba H, Kodama T, Takeda K, Hosoda Y, Yagita H, Okumura K. Expression and function of 4-1BB and 4-1BB ligand on murine dendritic cells. *Int Immunol* 2002;14:275-86.
- Hurtado JC, Kim YJ, Kwon BS. Signals through 4-1BB are costimulatory to previously activated splenic T cells and inhibit activation-induced cell death. *J Immunol* 1997;158:2600-9.
- Wilcox RA, Flies DB, Zhu G, Johnson AJ, Tamada K, Chapoval AI, Strome SE, Pease LR, Chen L. Provision of antigen and CD137 signaling breaks immunological ignorance, promoting regression of poorly immunogenic tumors. *J Clin Invest* 2002;109:651-9.
- Kim JA, Averbuck BJ, Chambers K, Rothchild K, Kjaergaard J, Papay R, Shu S. Divergent effects of 4-1BB antibodies on antitumor immunity and on tumor-reactive T-cell generation. *Cancer Res* 2001;61:2031-7.
- Vicari AP, Ait-Yahia S, Chemin K, Mueller A, Zlotnik A, Caux C. Antitumor effects of the mouse chemokine 6CKine/SLC through

- angiostatic and immunological mechanisms. *J Immunol* 2000;165:1992–2000.
25. Arenberg DA, Polverini PJ, Kunkel SL, Shanafelt A, Hesselgesser J, Horuk R, Strieter RM. The role of CXC chemokines in the regulation of angiogenesis in non-small cell lung cancer. *J Leukoc Biol* 1997;62:554–62.
 26. Miller RE, Jones J, Le T, Whitmore J, Boiani N, Gliniak B, Lynch DH. 4-1BB-specific monoclonal antibody promotes the generation of tumor-specific immune responses by direct activation of CD8 T cells in a CD40-dependent manner. *J Immunol* 2002;169:1792–800.
 27. Taraban VY, Rowley TF, O'Brien L, Chan HT, Haswell LE, Green MH, Tutt AL, Glennie MJ, Al-Shamkhani A. Expression and costimulatory effects of the TNF receptor superfamily members CD134 (OX40) and CD137 (4-1BB), and their role in the generation of anti-tumor immune responses. *Eur J Immunol* 2002;32:3617–27.
 28. Wilcox RA, Tamada K, Strome SE, Chen L. Signaling through NK cell-associated CD137 promotes both helper function for CD8⁺ cytolytic T cells and responsiveness to IL-2 but not cytolytic activity. *J Immunol* 2002;169:4230–6.
 29. Xu D, Gu P, Pan PY, Li Q, Sato AI, Chen SH. NK and CD8⁺ T cell-mediated eradication of poorly immunogenic B16-F10 melanoma by the combined action of IL-12 gene therapy and 4-1BB costimulation. *Int J Cancer* 2004;109:499–506.
 30. Diehl L, van Mierlo GJ, den Boer AT, van der Voort E, Fransen M, van Bostelen L, Krimpenfort P, Melief CJ, Mittler R, Toes RE, Offringa R. In vivo triggering through 4-1BB enables Th-independent priming of CTL in the presence of an intact CD28 costimulatory pathway. *J Immunol* 2002;168:3755–62.
 31. Melero I, Shuford WW, Newby SA, Aruffo A, Ledbetter JA, Hellstrom KE, Mittler RS, Chen L. Monoclonal antibodies against the 4-1BB T-cell activation molecules eradicate established tumors. *Nat Med* 1997;3:682–5.
 32. Ito F, Li Q, Shreiner AB, Okuyama R, Jure-Kunkel MN, Teitz-Tennenbaum S, Chang AE. Anti-CD137 monoclonal antibody administration augments the antitumor efficacy of dendritic cell-based vaccines. *Cancer Res* 2004;64:8411–19.
 33. Cuadros C, Dominguez AL, Lollini PL, Croft M, Mittler RS, Borgstrom P, Lustgarten J. Vaccination with dendritic cells pulsed with apoptotic tumors in combination with anti-OX40 and anti-4-1BB monoclonal antibodies induces T cell-mediated protective immunity in Her-2/neu transgenic mice. *Int J Cancer* 2005;116:934–43.
 34. Szmania S, Galloway A, Bruorton M, Musk P, Aubert G, Arthur A, Pyle H, Hensel N, Ta N, Lamb LJ, Dodi T, Madrigal A et al. Isolation and expansion of cytomegalovirus-specific cytotoxic T lymphocytes to clinical scale from a single blood draw using dendritic cells and HLA-tetramers. *Blood* 2001;98:505–12.